



McIntosh Laboratory, Inc. 2 Chambers Street Binghamton, New York 13903-2699 Phone: 607-723-3512 www.mcintoshlabs.com

MC1.25KW
Quad Balanced
Power Amplifier
Owner's Manual





Important Safety Information is supplied in a separate document “Important Additional Operation Information Guide”

Thank You

Your decision to own this McIntosh MC1.25KW Quad Balanced Power Amplifier ranks you at the very top among discriminating music listeners. You now have “The Best.” The McIntosh dedication to “Quality,” is assurance that you will receive many years of musical enjoyment from this unit.

Please take a short time to read the information in this manual. We want you to be as familiar as possible with all the features and functions of your new McIntosh.

Please Take A Moment

The serial number, purchase date and McIntosh Dealer name are important to you for possible insurance claim or future service. The spaces below have been provided for you to record that information:

Serial Number: _____

Purchase Date: _____

Dealer Name: _____

Technical Assistance

If at any time you have questions about your McIntosh product, contact your McIntosh Dealer who is familiar with your McIntosh equipment and any other brands that may be part of your system. If you or your Dealer wish additional help concerning a suspected problem, you can receive technical assistance for all McIntosh products at:

McIntosh Laboratory, Inc.
2 Chambers Street
Binghamton, New York 13903
Phone: 607-723-3512
Fax: 607-724-0549

Customer Service

If it is determined that your McIntosh product is in need of repair, you can return it to your Dealer. You can also return it to the McIntosh Laboratory Service Department. For assistance on factory repair return procedure, contact the McIntosh Service Department at:

McIntosh Laboratory, Inc.
2 Chambers Street
Binghamton, New York 13903
Phone: 607-723-3515
Fax: 607-723-1917

Table of Contents

Safety Instructions..... 2
 (Separate Sheet) **Important Additional Operation Information Guide**

Thank You and Please Take a Moment 2
 Technical Assistance and Customer Service..... 2
 Table of Contents 2
 General Information 3
 Connector and Cable Information 3
 Introduction..... 4
 Performance Features 4
 Dimensions 5
 Installation 6
 Rear Panel Connections and Switch 7
 Output Terminals and How to Connect 8-9
 Output Terminals and How to Connect
 for Bi-Amp 10-11
 Front Panel Displays and Controls..... 12
 How to Operate 13
 Technical Description 14-17
 Specifications 18
 Packing Instruction..... 19

General Information

Caution: The MC1.25KW Amplifier weight is 158 pounds (71.7 kilograms). It requires two or more persons to safely handle when moving the amplifier.

- 1. For additional connection information, refer to the owner's manual(s) for any component(s) connected to the MC1.25KW.
2. The MC1.25KW mutes the speaker output for approximately two seconds when first turned on.
3. For the best performance and safety it is important to always match the impedance of the Loudspeaker to the Power Amplifier connections. Refer to "How to Connect" pages 8 thru 11.

Note: The impedance of a Loudspeaker actually varies as the Loudspeaker reproduces different frequencies. As a result, the nominal impedance rating of the Loudspeaker (usually measured at a midrange frequency) might not always agree with the impedance of the Loudspeaker at low frequencies where the greatest amount of power is required. Contact the Loudspeaker Manufacturer for additional information about the actual impedance of the Loudspeaker before connecting it to the McIntosh MC1.25KW.

- 4. It is very important that loudspeaker cables of adequate size be used, so that there will be no power loss. The size is specified in Gauge Numbers or AWG, (American Wire Gauge). The smaller the Gauge number, the larger the wire size:

If your loudspeaker cables are 50 feet (38.1m) or less, use at least 14 Gauge.

If your loudspeaker cables are 100 feet (76.2m) or less, use at least 12 Gauge.

- 5. The MC1.25KW incorporates the very latest in Fully Double Balanced Circuitry. As a result, the Loudspeaker Negative Connections are above chassis ground. Do not combine any connections together, ground them or connect with another MC1.25KW.
6. In the event the MC1.25KW over heats, due to improper ventilation and/or high ambient temperature, the protection circuits will activate. The Front Panel Power Guard LED will continuously indicate ON and the audio will be muted. When the MC1.25KW has returned to a safe operating temperature, normal operation will resume.
7. When discarding the unit, comply with local rules or regulations. Batteries should never be thrown away or incinerated but disposed of in accordance with the local regulations concerning battery disposal.
8. For additional information on the MC1.25KW and other McIntosh Products please visit the McIntosh Web Site at www.mcintoshlabs.com.



Connector and Cable Information

XLR Connectors

Below is the Pin configuration for the XLR Balanced Input, Input/Output Connectors on the MC1.25KW.

Refer to the diagram for connection:

- PIN 1: Shield/Ground
PIN 2: + Input/Output
PIN 3: - Input/Output

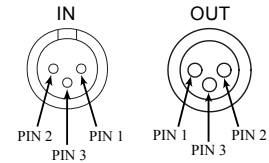

Power Control Connector

The MC1.25KW Power Control Input (Trigger Control) receives an On/Off signal from +5 to +12 volts.

The Power Control Output will in turn provide a +12 volt Output Signal with a total current up to 50mA. An additional connection is for controlling the illumination of the McIntosh

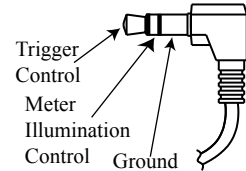

Power Output Meters. The 3.5mm stereo mini phone plug connects to another McIntosh Power Amplifier.

Output Terminal Connector

When cables with spade lugs are used for Loudspeaker Connection, the spade lugs need an opening of at least 3/10 inch (7.6mm)

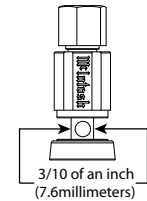



Introduction

Now you can take advantage of traditional McIntosh standards of excellence in the MC1.25KW Quad Balanced Power Amplifier. The 1200 watts high current output will drive any high quality Loudspeaker. The MC1.25KW reproduction is sonically transparent and absolutely accurate. The McIntosh Sound is “The Sound of the Music Itself.”

Performance Features

• Power Output

The MC1.25KW is a Power Amplifier with a capability of 1200 watts into 2, 4 or 8 ohm speakers with less than 0.005% distortion. The Power Amplifier Circuitry uses Thermal Trak¹ Output Transistors for lower distortion and cool operation.

• Full Balanced Quad-Differential Circuitry

The MC1.25KW is fully balanced from input to output. It consists of two matched Power Amplifiers operating in push-pull with their outputs combined in a McIntosh Autoformer. The Quad Balanced configuration cancels virtually all distortion.

• Patented Autoformer

McIntosh designed and manufactured Output Autoformers provide an ideal match between the amplifier output stages and speaker loads of 2, 4 and 8 ohms. The Autoformers also provide perfect DC protection for your valuable loudspeakers.

• Balanced and Unbalanced Inputs

Balanced connections guard against induced noise and allow long cable runs without compromising sound quality.

¹ ThermalTrak™ and ON Semiconductor are trademarks of Semiconductor Components Industries, LLC

• Power Guard

The patented McIntosh Power Guard circuit prevents the amplifier from being over driven into clipping, with its harsh distorted sound that can also damage your valuable loudspeaker.

• Sentry Monitor and Thermal Protection

McIntosh Sentry Monitor power output stage protection circuits ensure the MC1.25KW will have a long and trouble free operating life. Built-in Thermal Protection Circuits guard against overheating.

• Special Power Supply

A regulated Power Supply, a very large Toroidal Wound Power Transformer and very large capacitors ensures stable noise free operation even though the power line varies.

• Illuminated Power Meter

The Illuminated Power Output Watt Meter on the MC1.25KW is peak responding, and indicates the true power output of the Amplifier. The Peak Watt Hold Mode allows the meter to temporarily stay at the highest power output and then slowly decay. The Front Panel Meter Illumination may be switched Off at any time.

• McIntosh Custom Binding Posts

McIntosh patent pending gold plated output terminals deliver high current output. They accept large diameter wire and spade lugs. Banana plugs may also be used only in the United States and Canada.

• Fiber Optic Solid State Front Panel Illumination

The even Illumination of the Front Panel is accomplished by the combination of custom designed Fiber Optic Light Diffusers and extra long life Light Emitting Diodes (LEDs).

• Glass Front Panel and Super Mirror Chassis Finish

The famous McIntosh Illuminated Glass Front Panel uses long life Light Emitting Diodes (LEDs) and the Stainless Steel Chassis with Super Mirror Finish ensures the pristine beauty of the MC1.25KW will be retained for many years.

Dimensions

The following dimensions can assist in determining the best location for your MC1.25KW.

Front View of the MC1.25KW

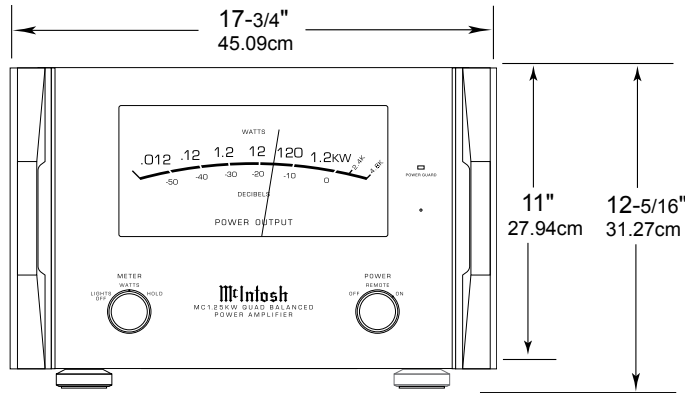

Side View of the MC1.25KW

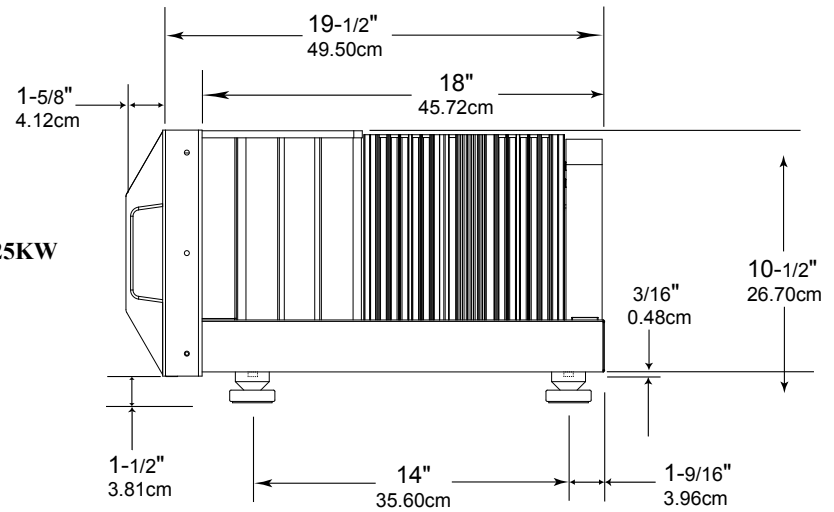

Rear View of the MC1.25KW

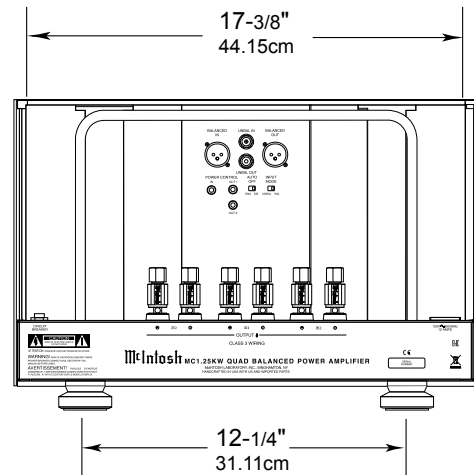

Installation

The MC1.25KW can be placed upright on a table or shelf, standing on its four feet. It also can be custom installed in a piece of furniture or cabinet of your choice. The four feet may be removed from the bottom of the MC1.25KW when it is custom installed as outlined below. The four feet together with the mounting screws should be retained for possible future use if the MC1.25KW is removed from the custom installation and used free standing. The required panel cutout, ventilation cutout and unit dimensions are shown.

Always provide adequate ventilation for your MC1.25KW. Cool operation ensures the longest possible operating life for any electronic instrument. Do not install the MC1.25KW directly above a heat generating component such as a high powered amplifier. If all the components are installed in a single cabinet, a quiet running ventilation fan can be a definite asset in maintaining all the system components at the coolest possible operating temperature.

A custom cabinet installation should provide the following minimum spacing dimensions for cool operation.

Allow at least 6 inches (15.24cm) above the top, 2 inches (5.08cm) below the bottom, 3 inches (7.62cm) behind the rear panel and 2 inches (5.08cm) on each side of the Power Amplifier, so that airflow is not obstructed. Allow 2-1/2 inches (6.35 cm) in front of the mounting¹ panel for clearance. **Be sure to cut out a ventilation hole in the mounting shelf according to the dimensions in the drawing.**

¹ When the MC1.25KW is installed together with other McIntosh Components, check clearances on all components before proceeding.

MC1.25KW Front Panel
Custom Cabinet Cutout

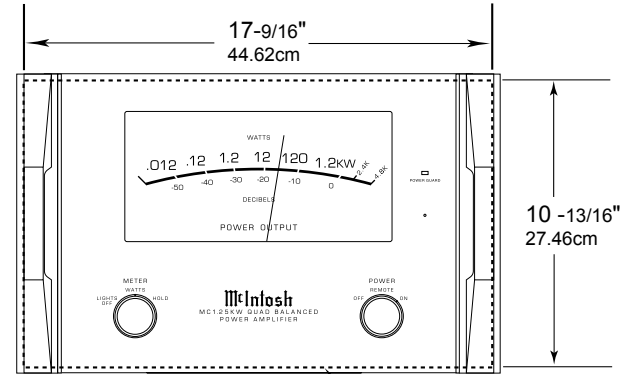

MC1.25KW Side View
in Custom Cabinet

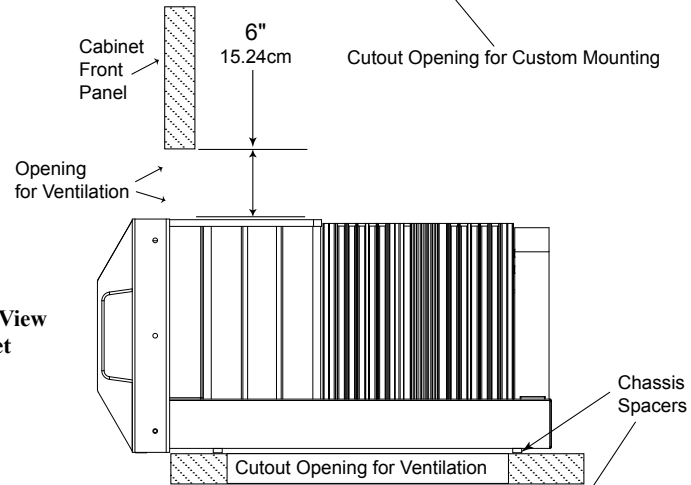

MC1.25KW Bottom View
in Custom Cabinet

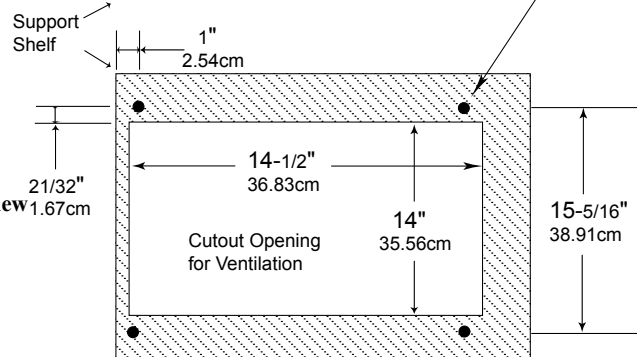

Rear Panel Connections and Switch

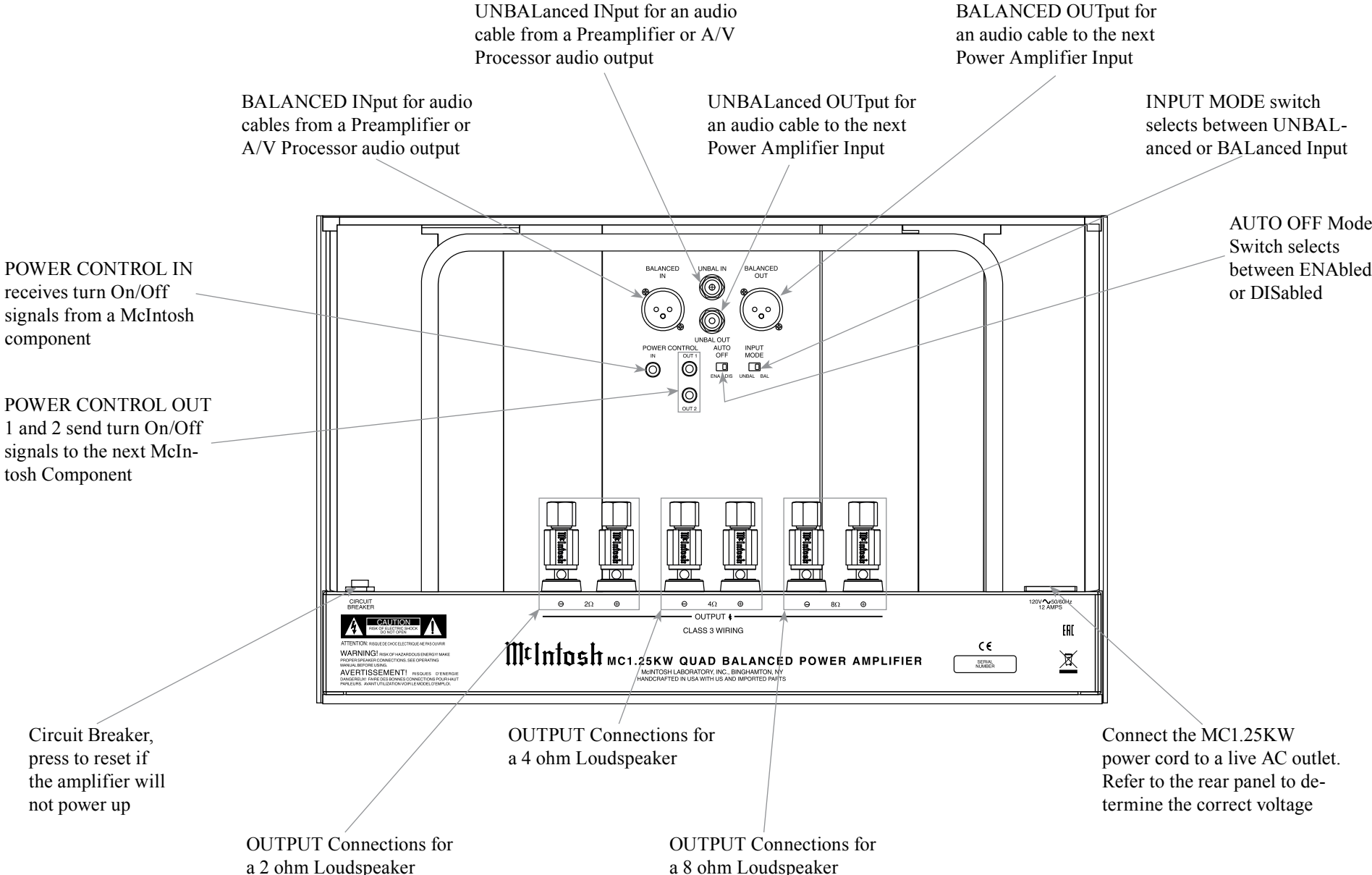

Caution: The Loudspeaker ⊖ Negative Connections are above chassis ground. Do not combine any connections together, ground them or connect with another MC1.25KW.



Output Terminals

When connecting the Loudspeaker Hookup Cables to the MC1.25KW Power Amplifier Output Terminals please follow the steps below:

1. Rotate the top of the Output Terminal Post counterclockwise until an opening appears. Refer to figures A and B.
2. Insert the Loudspeaker hookup cable into the Output Terminal Post opening or the cable spade lug around the center post of the Output Terminal. Refer to figure C.
3. Rotate the top of the Output Terminal Post clockwise until it is finger tight. Refer to figure D.
4. Place the supplied McIntosh Wrench over the top of the Output Terminal and rotate it one quarter of a turn (90°) to secure the Loudspeaker Cable Connection. **Do not over tighten.** Refer to figure E.

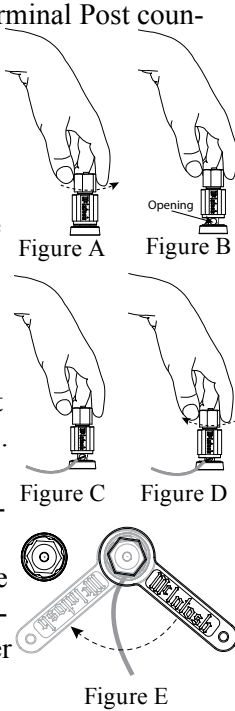

How to Connect

Caution: Do not connect the AC Power Cord to the MC1.25KW Rear Panel until after the Loudspeaker Connections are made and the protective Terminal Connections Cover is installed. Failure to observe this could result in Electric Shock.

The connection instructions below, together with the MC1.25KW Connection Diagram located on the separate folded sheet “Mc1A”, is an example of a typical audio system. Your system may vary from this, however the actual components would be connected in a similar manner. For additional information refer to

“Connector and Cable Information” on page 3.

1. For Remote Power Control, connect a power control cable from the Audio Preamplifier or A/V Processor Power Control Output Trigger 1 to the Amplifier POWER CONTROL IN.

Note: When a Power Control Cable is connected between the MC1.25KW and Preamplifier (or A/V Processor), the AUTO OFF Feature is bypassed. Refer to page 13.

2. Connect XLR cables from the Output 1 Balanced R, (refer to note 2 below) of an Audio Preamplifier or A/V Processor to the Amplifier BALANCED INPUT. Place the INPUT MODE Switch in the BALANCED Position.

Notes: 1. An optional hookup is to use unbalanced cable and place the INPUT MODE Switch in the UNBALANCED position.

2. When multiple MC1.25KW's are used in a Stereo or Multichannel System, match up the Preamplifier or A/V Processor Channel Output designation to each MC1.25KW with Loudspeaker and the Loudspeaker location in the room.

3. Using a suitable tool remove the two screws from each side of the MC1.25KW Rear Chassis Handle and temporarily place them in a safe place. Refer to figure 1.

This McIntosh MC1.25KW Quad Balanced Power Amplifier is designed for Loudspeakers with an impedance of 2 ohms, 4 ohms or 8 ohms. Connect a single Loudspeaker only to the Output Terminals.

When connecting Loudspeakers to the MC1.25KW it is very important to use cables of adequate size, so there is little to

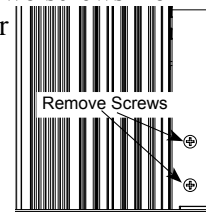

Figure 1

no power loss in the cables. The size is specified in Gauge Numbers or AWG (American Wire Gauge). The smaller the Gauge number, the larger the wire size:

Loudspeaker Cable Distance vs Wire Gauge Guide			
Loudspeaker Impedance	25 feet (7.62 meters) or less	50 feet (15.24 meters) or less	100 feet (30.48 meters) or less
2 Ohms	12AWG	10AWG	8AWG
4 Ohms	14AWG	12AWG	10AWG
8 Ohms	16AWG	14AWG	12AWG

4. Prepare the Loudspeaker Hookup Cable for attachment to the MC1.25KW Power Amplifier:

Bare wire cable ends:

Carefully remove sufficient insulation from the cable ends, refer to figures 2, 3 & 4. If the cable is stranded, carefully twist the strands together as tightly as possible.

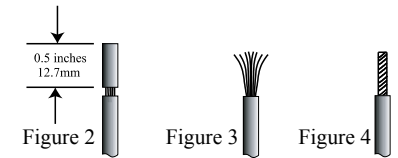

Notes: 1. If desired, the twisted ends can be tinned with solder to keep the strands together.

2. The prepared bare wire cable ends may be inserted into spade lug connectors.

3. Banana plugs are for use in the United States and Canada only.

Banana Plugs are for use in the United States and Canada only:

5. Locate the Terminal Connections Cover from the inside of the MC1.25KW shipping carton. Insert the just prepared Loudspeaker hookup cables thru the cover opening on the right side. Refer to figure 5.

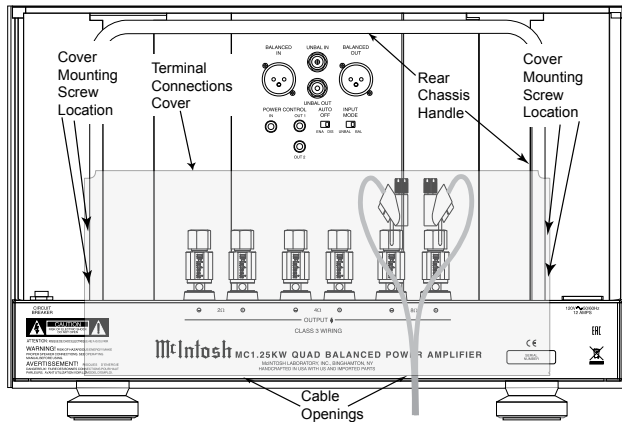

Figure 5 (Inside USA and Canada)

6. Attach the previously prepared bare wire cable ends into the banana plugs and secure the connections. Refer to figure F.

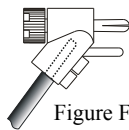

Figure F

7. Rotate the top of the Output Terminal Post clockwise until it is finger tight. Refer to figure G. Then using the McIntosh Wrench, rotate the top of the Output Terminal one quarter of a turn (90°). **Do not over tighten.** Refer to figure E.

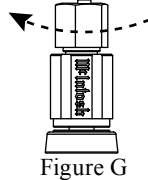

Figure G

8. Referring to figure H, connect the Loudspeaker hookup cables with banana plugs into the hole at the top of the MC1.25KW Negative and Positive Output Terminals. The terminals are identified as 2Ω (ohms), 4Ω (ohms) or 8Ω (ohms) connection to match the impedance of the Loudspeaker, being careful to observe the correct polarities.

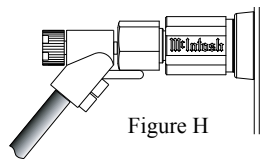

Figure H

Note: The illustration in figure 5 is connections for 8Ω (ohms) Loudspeakers.

If the Loudspeaker's impedance is in-between the available connections, use the nearest lower imped-

ance connection. Refer to "General Information" Note 3 on page 3 for additional information.

WARNING: Loudspeaker terminals are hazardous live and present a risk of electric shock. For additional instruction on making Loudspeaker Connections contact your McIntosh Dealer or McIntosh Technical Support.

9. Attach the Terminal Connections Cover to the MC1.25KW Rear Panel with the previously removed Screws. Refer to figure 5.
10. Connect the MC1.25KW power cord to an active AC outlet.

Spade Lug or Wire Connections:

11. Locate the Terminal Connections Cover from the inside of the MC1.25KW shipping carton. Insert the just prepared Loudspeaker hookup cables thru the cover opening on the right side. Refer to figure 6.

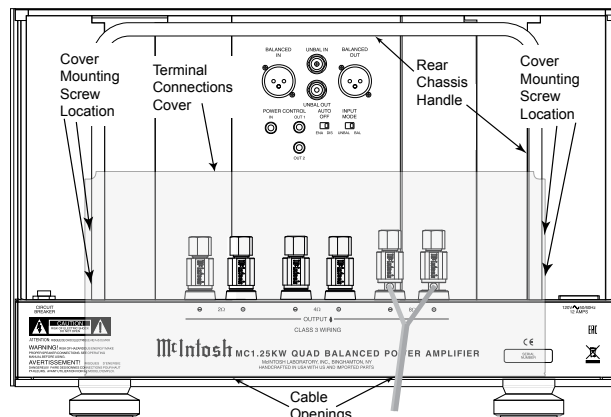

Figure 6 (Outside USA and Canada)

12. Connect the Loudspeaker hookup cables to the MC1.25KW Negative Output Terminal and Positive Output Terminal identified as 2Ω (ohms), 4Ω (ohms) or 8Ω (ohms) connection to match the

impedance of the Loudspeaker, being careful to observe the correct polarities. Insert the spade lug connector or prepared section of the cable end into the terminal side access hole, and tighten the terminal cap until the cable is firmly clamped into the terminals so the lugs or wire cannot slip out. Refer to figures 7 and 8.

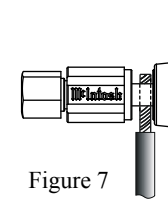

Figure 7

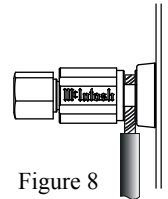

Figure 8

Note: The illustration in figure 6 is connections for 8Ω (ohms) Loudspeakers.

If the Loudspeaker's impedance is in-between the available connections, use the nearest lower impedance connection. Refer to "General Information" Note 4 on page 3 for additional information.

WARNING: Loudspeaker terminals are hazardous live and present a risk of electric shock. For additional instruction on making Loudspeaker Connections contact your McIntosh Dealer or McIntosh Technical Support.

13. Attach the Terminal Connections Cover to the MC1.25KW Rear Panel with the previously removed Screws. Refer to figure 6.
14. Connect the MC1.25KW power cord to an active AC outlet.

Output Terminals

When connecting the Loudspeaker Hookup Cables to the MC1.25KW Power Amplifier Output Terminals please follow the steps below:

1. Rotate the top of the Output Terminal Post counterclockwise until an opening appears. Refer to figures A and B.
2. Insert the Loudspeaker hookup cable into the Output Terminal Post opening or the cable spade lug around the center post of the Output Terminal. Refer to figure C.
3. Rotate the top of the Output Terminal Post clockwise until it is finger tight. Refer to figure D.
4. Place the supplied McIntosh Wrench over the top of the Output Terminal and rotate it one quarter of a turn (90°) to secure the Loudspeaker Cable Connection. **Do not over tighten.** Refer to figure E.

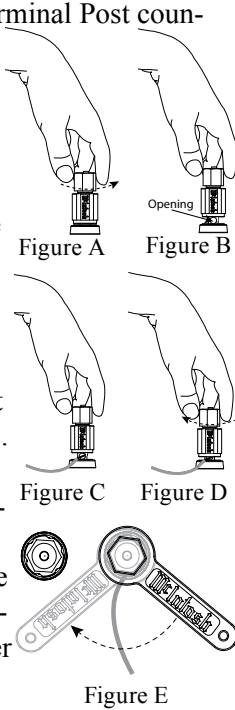

How to Connect for Bi-Amp

Caution: Do not connect the AC Power Cord to the MC1.25KW Rear Panel until after the Loudspeaker Connections are made and the protective Terminal Connections Cover is installed. Failure to observe this could result in Electric Shock.

The connection instructions below, together with the MC1.25KW Connection Diagram located on the separate folded sheet “Mc1B”, is an example of a typical audio system. Your system may vary from this, however the actual components would be connected in a similar manner. For additional information refer to

“Connector and Cable Information” on page 3.

1. For Remote Power Control, connect a power control cable from the Audio Preamplifier or A/V Processor Power Control Output Trigger 1 to Amplifier One POWER CONTROL IN.

Note: When the Power Control Cable is connected between the MC1.25KW and Preamplifier or A/V Processor, the AUTO OFF Power Save Feature is automatically disabled.

2. Connect a second power control cable from Amplifier One POWER CONTROL OUTput 1 to Amplifier Two POWER CONTROL IN.
3. Connect XLR cables from the Balanced Output 1 (R, refer to note 2 below) of an Audio Preamplifier or A/V Processor to Amplifier One BALANCED INput. Place the INPUT MODE Switch in the BALANCED Position.

*Notes: 1. An optional hookup is to use unbalanced cable and place the INPUT MODE Switch in the UNBALANCED Position.
2. When multiple MC1.25KW's are used in a Stereo or Multichannel System, match up the Preamplifier or A/V Processor Channel Output designation to each MC1.25KW with Loudspeaker and the Loudspeaker location in the room.*

4. Connect XLR cables from Amplifier One Audio BALANCED OUTput to Amplifier Two BALANCED INput.
5. Using a suitable tool remove the two screws from each side of the MC1.25KW Rear Chassis Handle and temporarily place them in a safe place. Refer to figure 1.

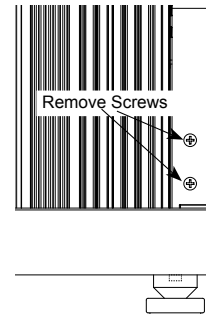

Figure 1

This McIntosh MC1.25KW Quad Balanced Power Amplifier is designed for Loudspeakers with an

impedance of 2 ohms, 4 ohms or 8 ohms. Connect a single Loudspeaker only to the Output Terminals.

When connecting Loudspeakers to the MC1.25KW it is very important to use cables of adequate size, so there is little to no power loss in the cables. The size is specified in Gauge Numbers or AWG (American Wire Gauge). The smaller the Gauge number, the larger the wire size:

Loudspeaker Cable Distance vs Wire Gauge Guide			
Loudspeaker Impedance	25 feet (7.62 meters) or less	50 feet (15.24 meters) or less	100 feet (30.48 meters) or less
2 Ohms	12AWG	10AWG	8AWG
4 Ohms	14AWG	12AWG	10AWG
8 Ohms	16AWG	14AWG	12AWG

6. Prepare the Loudspeaker Hookup Cable for attachment to the MC1.25KW Power Amplifier:

Bare wire cable ends:

Carefully remove sufficient insulation from the cable ends, refer to figures 2, 3 & 4. If the cable is stranded, carefully twist the strands together as tightly as possible.

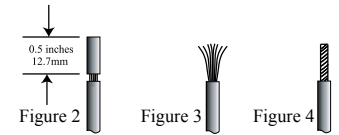

- Notes: 1. If desired, the twisted ends can be tinned with solder to keep the strands together.
2. The prepared bare wire cable ends may be inserted into spade lug connectors.
3. Banana plugs are for use in the United States and Canada only.*

Banana Plugs are for use in the United States and Canada only:

7. Locate the Terminal Connections Cover from inside MC1.25KW shipping carton. Insert the just prepared Loudspeaker hookup cables thru the cover opening on the right side. Refer to figure 5.

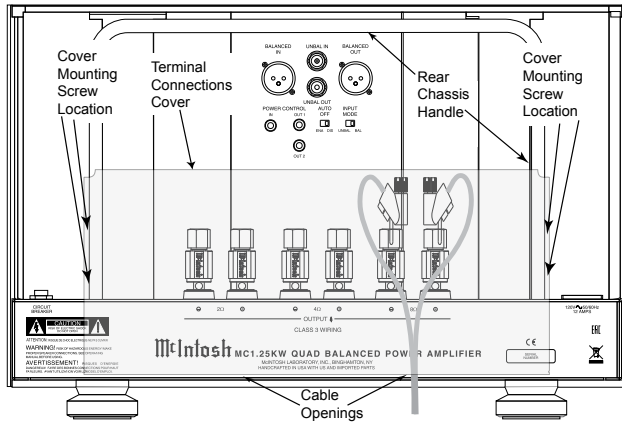

Figure 5 (Inside USA and Canada)

8. Attach the previously prepared bare wire cable ends into the banana plugs and secure the connections. Refer to figure F.

9. Rotate the top of the Output Terminal clockwise until it is finger tight. Refer to figure G. Then using the McIntosh Wrench, rotate the top of the Output Terminal one quarter of a turn (90°). **Do not over tighten.** Refer to figure E.

10. Referring to figure H, connect the Loudspeaker hookup cables with banana plugs into the hole at the top of the MC1.25KW Negative and Positive Output Terminals. The terminals are identified as 2Ω (ohms), 4Ω (ohms) or 8Ω (ohms) connection to match the impedance of the Loudspeaker, being careful to observe the correct polarities.

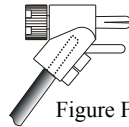

Figure F

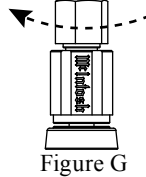

Figure G

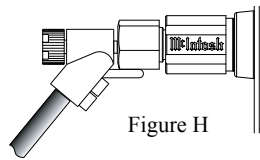

Figure H

Note: The illustration in figure 5 is connections for 8Ω (ohms) Loudspeakers.

If the Loudspeaker's impedance is in-between the available connections, use the nearest lower impedance connection. Refer to "General Information" Note 3 on page 3 for additional information.

WARNING: Loudspeaker terminals are hazardous live and present a risk of electric shock. For additional instruction on making Loudspeaker Connections contact your McIntosh Dealer or McIntosh Technical Support.

11. Attach the Terminal Connections Cover to the MC1.25KW Rear Panel with the previously removed Screws. Refer to figure 5.
12. Connect the MC1.25KW power cord to an active AC outlet.

Spade Lug or Wire Connections:

13. Locate the Terminal Connections Cover from the inside of the MC1.25KW shipping carton. Insert the just prepared Loudspeaker hookup cables thru the cover opening on the right side. Refer to figure 6.

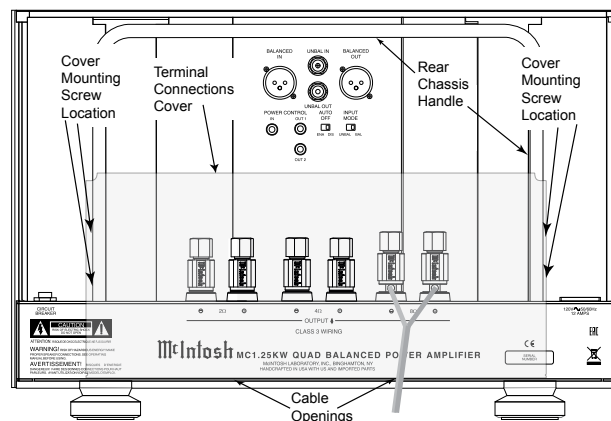

Figure 6 (Outside USA and Canada)

14. Connect the Loudspeaker hookup cables to the MC1.25KW Negative Output Terminal and Positive Output Terminal identified as 2Ω (ohms), 4Ω (ohms) or 8Ω (ohms) connection to match the impedance of the Loudspeaker, being careful to observe the correct polarities. Insert the spade lug connector or prepared section of the cable end into the terminal side access hole, and tighten the terminal cap until the cable is firmly clamped into the terminals so the lugs or wire cannot slip out. Refer to figures 7 and 8.

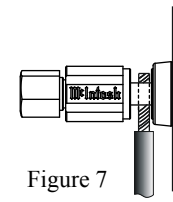

Figure 7

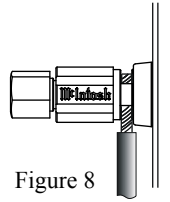

Figure 8

Note: The illustration in figure 6 is connections for 8Ω (ohms) Loudspeakers.

If the Loudspeaker's impedance is in-between the available connections, use the nearest lower impedance connection. Refer to "General Information" Note 3 on page 3 for additional information.

WARNING: Loudspeaker terminals are hazardous live and present a risk of electric shock. For additional instruction on making Loudspeaker Connections contact your McIntosh Dealer or McIntosh Technical Support.

15. Attach the Terminal Connections Cover to the MC1.25KW Rear Panel with the previously removed Screws. Refer to figure 6.
16. Connect the MC1.25KW power cord to an active AC outlet.

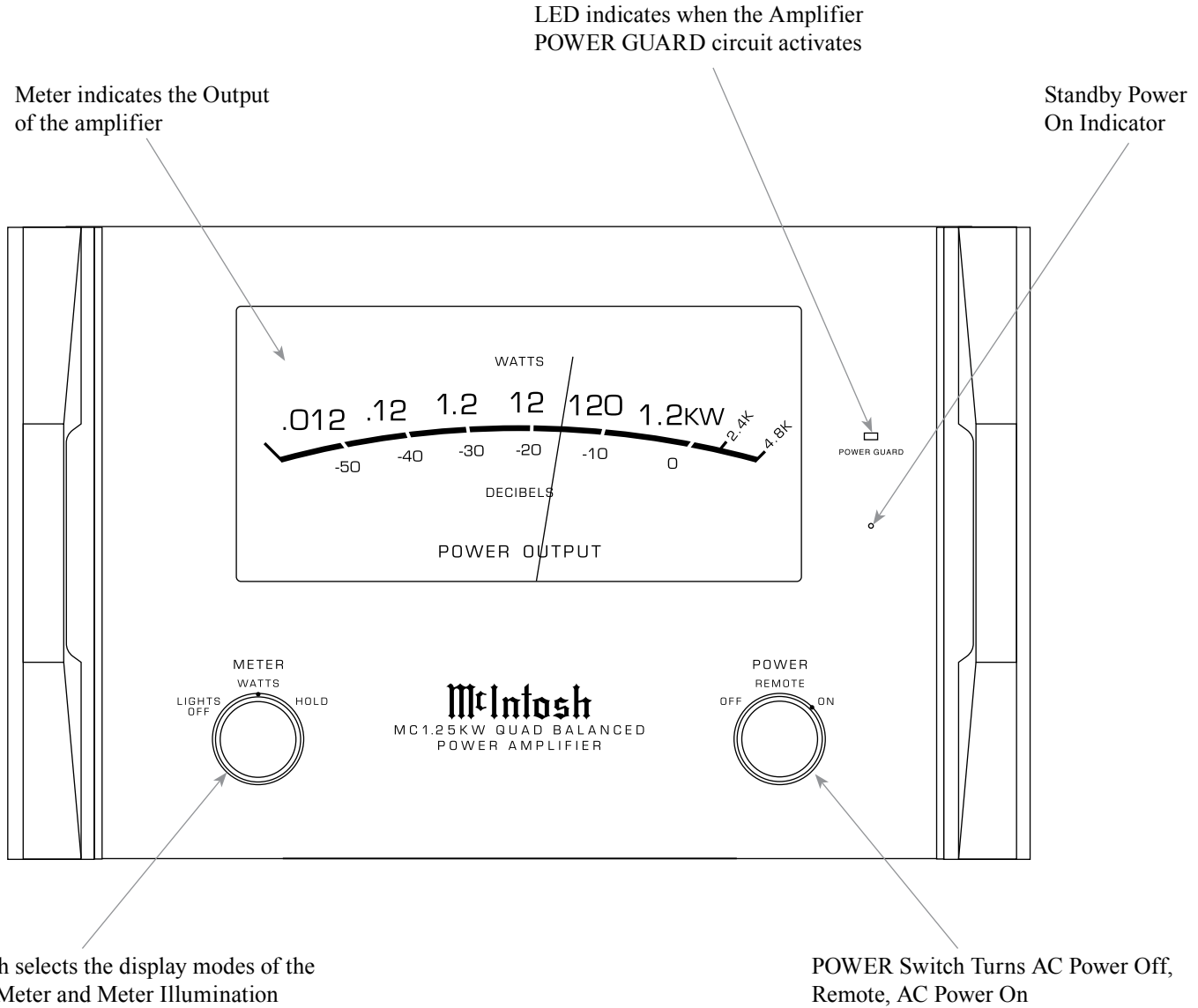

How to Operate

Power On

To have the MC1.25KW automatically turn On or Off when a Preamplifier or Control Center turns On or Off, rotate the power switch to the remote position. For manual operation, rotate the power switch to the On or Off position as desired. Refer to figure 8.

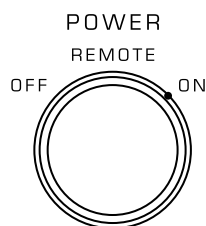

Figure 8

Note: There must be a power control connection between the MC1.25KW and the McIntosh Control Center, in order for the remote power turn-on to function.

Meter Selection

Rotate the meter mode switch to select the meter operation mode you desire. Refer to figures 9 and 10.

Lights Off - Meter lights are turned off and the meter will continue to indicate the power output.

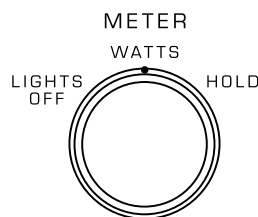

Figure 9

Note: When Power Control Input of the MC1.25KW is connected to a McIntosh A/V Processor or Preamplifier with Remote Meter Illumination Control, the Meter Illumination will automatically be remotely controlled (On/Off) with the METER Switch set to the WATTS or HOLD position.

Watts- The meters respond to all the musical information being produced by the amplifier. They indicate to an accuracy of at least 95% of the power output with

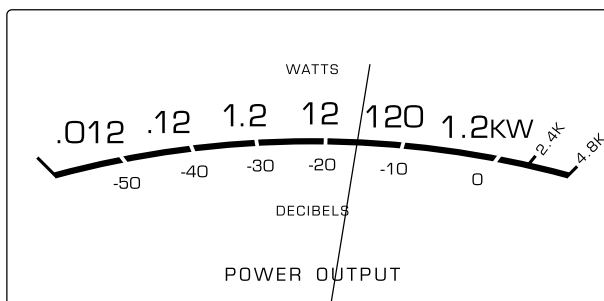

Figure 10

only a single cycle of a 2000Hz tone burst.

Hold - The meter pointer is locked to the highest power peak in a sequence of peaks. It is electronically held to this power level until a higher power peak passes through the amplifier. The meter pointer will then rise to the newer higher indication. If no further power peaks are reached, the meter pointer will very slowly return to its rest position or lower power level. The decay rate is approximately 6dB per minute.

Note: The MC1.25KW Power Output Meter indicates the actual wattage delivered to the loudspeakers by responding to the combination of current and voltage output.

Input Mode Switch

The Input Mode Switch, which is located on the Rear Panel of the MC1.25KW, allows you to select either the BALANCED or UNBALANCED Input. Refer to figure 11.

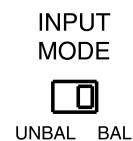

Figure 11

Auto Off Switch

The MC1.25KW incorporates Power Save Circuitry to automatically place the MC1.25KW into the power saving Standby Mode approximately 30 minutes after there has been an absence of an audio input signal.

When there is a Power Control Connection between the MC1.25KW and a Preamplifier with Power Save Circuitry, the AUTO OFF Switch is bypassed (located on the Rear Panel Of the MC1.25KW). Refer to figure 12.

In the event there is no Power Control Connection and the Power Save Circuitry is activating inappropriately relative to your specific use of the MC1.25KW, place the AUTO OFF Switch in the DISABLE position.

Note: If the Power Save Circuitry has switched Power to the MC1.25KW OFF, place the POWER in the OFF Position and then in the ON position to reset the circuitry.



Figure 12



Technical Description

McIntosh Laboratory, the company who introduced the world's first amplifier that could be called "High Fidelity", has done it again. The McIntosh engineering staff has created a power amplifier without compromise, using the most advanced McIntosh circuit design concepts. Refer to figure 13.

A continuous average power output rating of 1,200 watts and with an output current of 200 amperes, makes this one of the most advanced and most powerful amplifier McIntosh has ever manufactured. The distortion limits for the MC1.25KW are no more than 0.005% at rated power output for all frequencies from 20Hz to 20,000Hz. Typical performance at mid frequencies is less than 0.002%. The true distortion readings on the MC1.25KW are so low, it takes special measuring techniques to make accurate readings. The MC1.25KW can deliver the best possible performance from any type of high quality loudspeaker system.

Creating an amplifier with this level of performance did not come easily. Many months of design, testing and measuring were required. Extensive controlled listening tests, the ultimate form of measuring, were made before the final design was accepted.

Design Philosophy

The design philosophy incorporated in the MC1.25KW involved several different techniques, all based on sound scientific logic. Every stage of voltage or current amplification must be as linear as possible prior to the use of negative feedback. McIntosh engineers know how to properly

design negative feedback circuits so they contribute to the extremely low distortion performance expected from a McIntosh amplifier. The typical McIntosh owner would never accept the approximately 100 times higher distortion of many non-feedback designs.

Double Balanced Push-Pull design is used from input to output. Each half of the amplifier contains complimentary balanced circuitry. The resulting double balanced configuration cancels even order distortion. Refer to figure 14.

All transistors are selected to have nearly constant current gain over the entire current range they must cover. Output transistors in particular, have matched uniform current gain, high current bandwidth product and large active region safe operating area. These Power Transistors are the very latest in semiconductor technology and incorporate a new design known as ThermalTrak™. Refer to figure 15. This allows for the instantaneous and accurate monitoring of the Power Transistor Temperature. The MC1.25KW Power Output Circuitry has a specially designed bias circuit to take full advantage of the ThermalTrak™ Power Transistors and thus precisely controls the power amplifier operation over a wide range of music conditions with the benefits of lower distortion and cooler operation. Precision metal film resistors and low dielectric absorption film capacitors are used in all critical circuit locations.

The output signals of the two balanced circuits are coupled together in the unique McIntosh MC1.25KW Output Autoformer. It provides low distortion power transfer at frequencies from below 20Hz to well beyond 20,000Hz with optimum impedance points of two ohms, four ohms and eight ohms. The unequaled

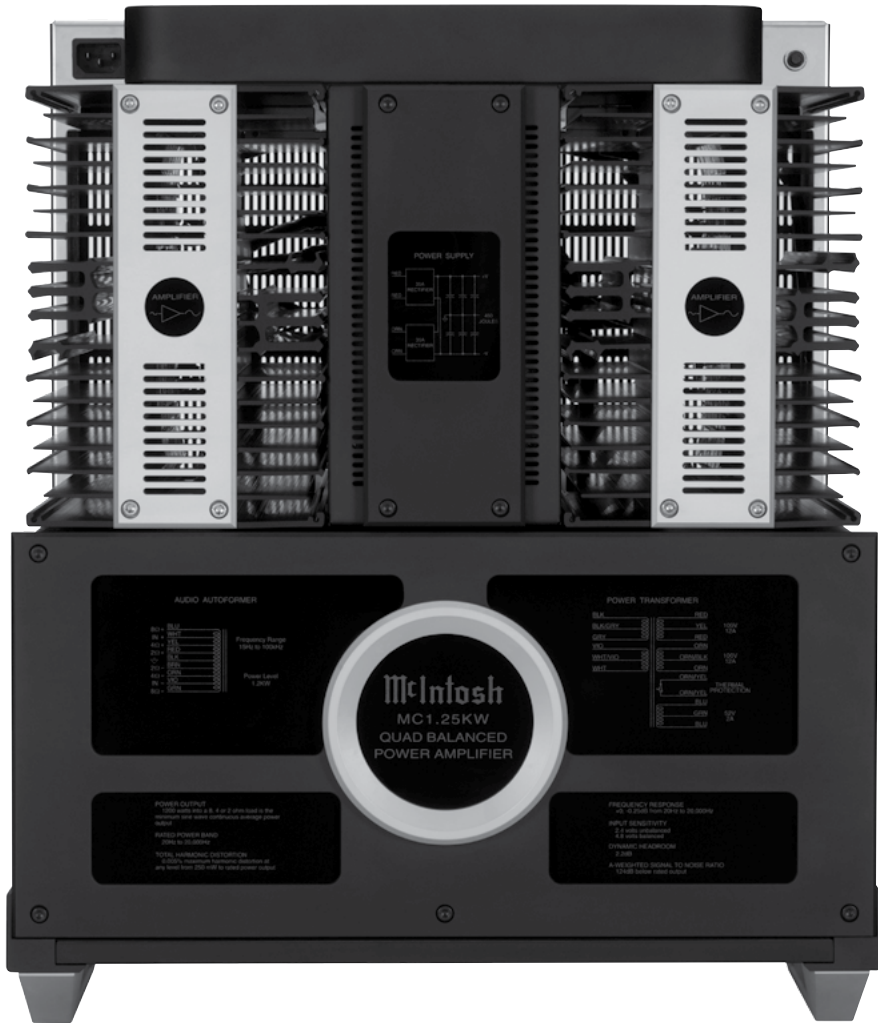

Figure 13

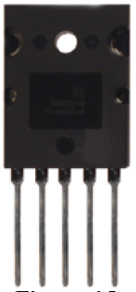

Figure 15

expertise of McIntosh in the design and manufacturing of autoformers is legendary in the high fidelity industry.

The high efficiency circuit design of the MC1.25KW contributes to low operating temperatures. More than 2800 square inches of heatsink area keep the MC1.25KW operating safely with convection cooling. No fans are needed. Refer to figure 16.

Autoformers

All solid state power amplifier output circuits work best into what is called an optimum load. This optimum load may vary considerably from what a loudspeaker requires. In the case of more than one loudspeaker connected in parallel, the load to the power amplifier may drop to two ohms or even less. A power amplifier connected to a load that is lower

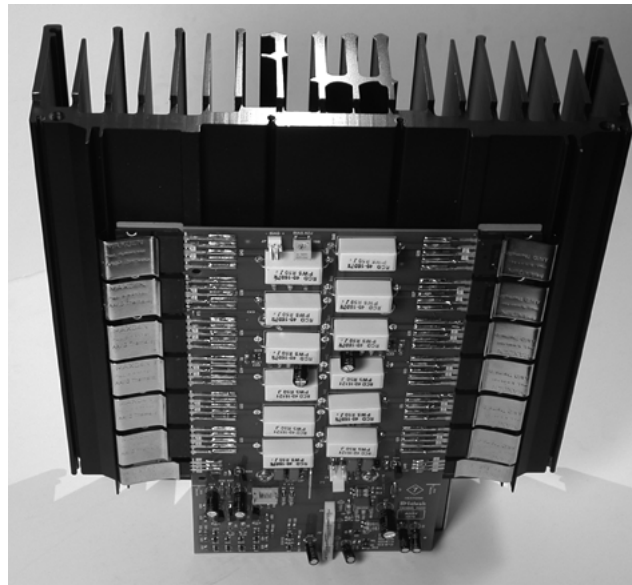
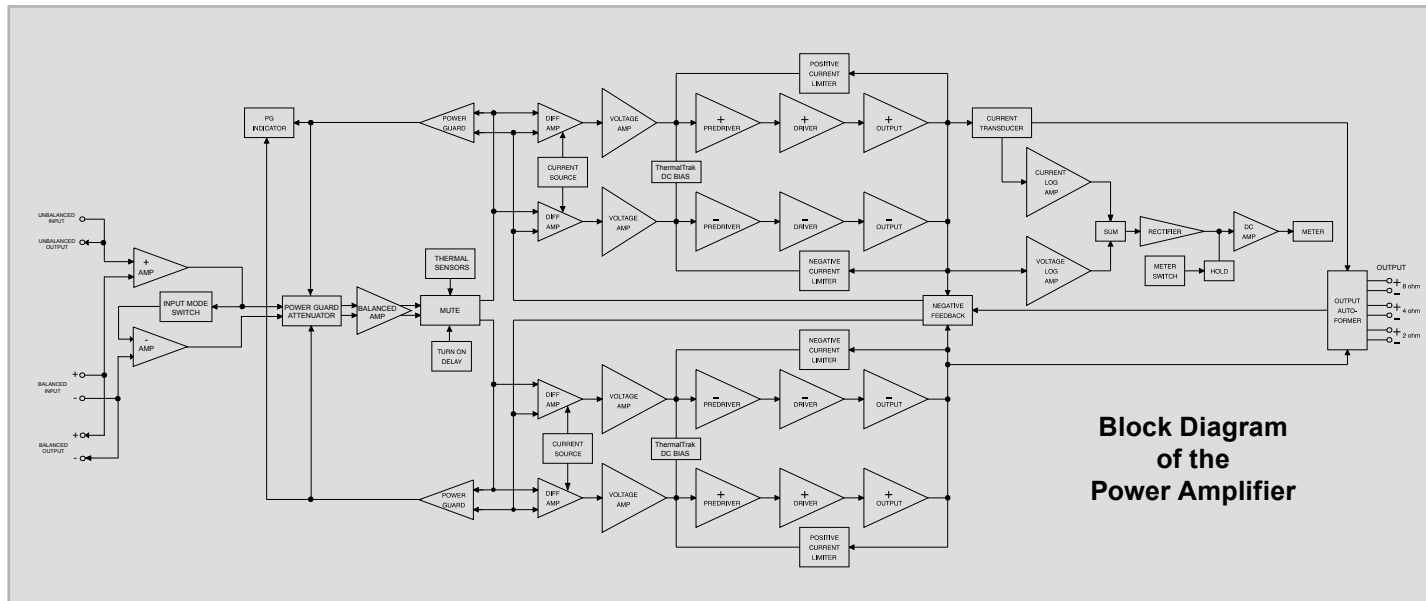

Figure 16



Figure 17



Block Diagram of the Power Amplifier

Figure 14

than optimum, causes more output current to flow, which results in extra heat being generated in the power output stage. This increase in temperature will result in a reduced life expectancy for the amplifier.

The special Balanced Dual Core Autoformer creates an ideal match between the power amplifier output stage and the loudspeaker. A McIntosh amplifier with an Autoformer can be used to safely drive multiple speakers without reducing the life expectancy of the power amplifier. Refer to figure 17.

There is absolutely no performance limitation with an Autoformer. Its frequency response exceeds that of the output circuit itself, and extends well beyond the audible range. Its distortion level is so low it is virtually impossible to measure.

Technical Description, con't

In the rare event of a power amplifier output circuit failure, the McIntosh Autoformer provides absolute protection from possible damage to your valuable loudspeakers. The unequaled expertise of McIntosh in the design and manufacturing of Autoformers is legendary in the high fidelity industry. McIntosh engineers know how to do it right.

Power Output Meter

The McIntosh MC1.25KW has a huge hand built Output Watt Meter that responds 95% full scale to a single cycle tone burst at 2kHz. Refer to figure 18.

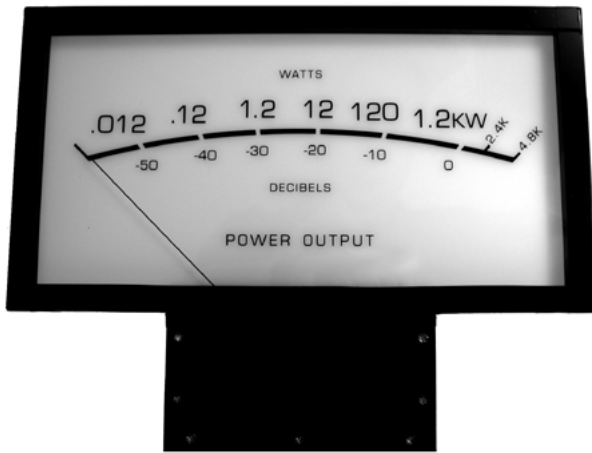

Figure 18

Voltage and current outputs are electronically measured, multiplied and fed to a special circuit that accelerates the pointer movement in the upward direction. When the pointer reaches its peak it pauses only long enough for the human eye to perceive its position, then drops. It is almost 10 times faster than a professional VU meter.

A front panel switch is provided to change the meter to the Watts Hold Mode of operation. This allows fast upward movement of the pointer but greatly increases Hold Time at the peak of its travel. The

highest power output of the source material is thus recorded.

Protection Circuits

The MC1.25KW incorporates a version of the McIntosh Sentry Monitor Output Transistor Protection Circuit. Refer to Figure 19. There is absolutely no compromise in sonic performance with this circuit, and it ensures safe operation of the amplifier under even the most extreme operating conditions. The different types of protection circuits incorporated in the MC1.25KW insure a long and safe operating life. This is just one of the many characteristics of McIntosh Power Amplifiers that make them world famous.

The MC1.25KW also includes the unique patented McIntosh Power Guard circuit. Power Guard eliminates the possibility of ever overdriving the amplifier into clipping. Refer to figures 20, 21 and 22. An overdriven amplifier can produce both audible and inaudible distortion levels exceeding 40%. The audible distortion is unpleasant to hear, but

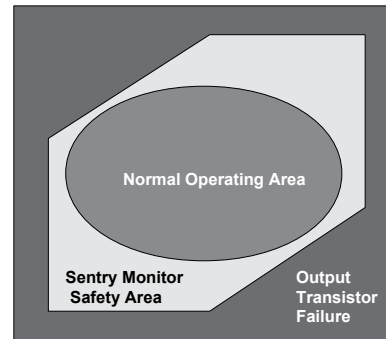

Figure 19

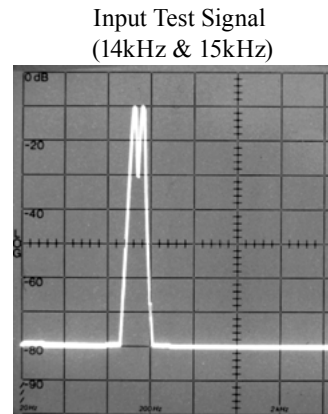

Figure 20

the inaudible ultrasonic distortion is also undesirable, since it can damage valuable loudspeaker system tweeters. You will never experience the harsh and damaging distortion due to clipping.

The Power Guard circuit is a waveform comparator, monitoring both the input and output waveforms. Under normal operating conditions, there are no differences between the shape of these waveforms. If an amplifier channel is overdriven, there will be a difference between the two signal waveforms. When the difference exceeds 0.3%, the Power Guard activates the PG light and a dynamic electronic attenuator

at the amplifier input reduces the input volume just enough to prevent any further increase in distortion. The Power Guard circuit acts so fast that there are absolutely no audible side effects and the sonic purity of the music reproduction is perfectly preserved. The MC1.25KW Power Amplifier with Power Guard is not limited to just the rated power output, but will actually produce distortion free output well above its rated power due to the McIntosh philosophy of conservative design.

Without Power Guard

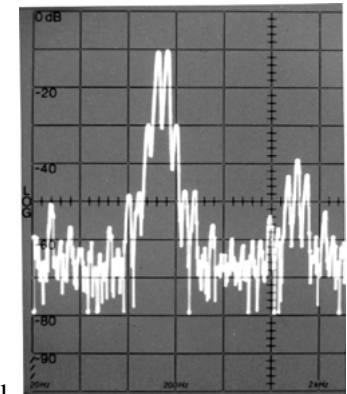

Figure 21

With Power Guard

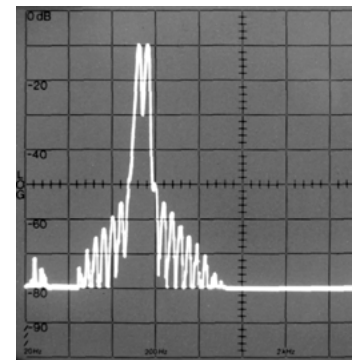

Figure 22

Power Supply Circuits

To compliment the fully balanced design of the MC1.25KW there are two high voltage power supplies; one for each of the two amplifier circuits, allowing each amplifier circuit to be optimized using its own power supply. Refer to figure 23. High power amplifiers draw high current from the AC power line. The very large Power Transformer, has toroidal windings on a toroidal core and can supply over 35 amps of continuous current. Refer to figure 24 (golf ball is for size comparison). It is enclosed in the legendary McIntosh Potted Enclosures and weighs over 12.06kg. The six super size main filter capacitors can store over 450 Joules of energy necessary for the wide dynamic range that “Digital Audio” demands. Refer to figure 25. The power amplifier draws high current from the AC power line. Therefore, it is important that they plug directly into the wall outlet.

Also, most owners desire one power switch for the whole audio system. The MC1.25KW is equipped with a circuit that provides remote Power Control from a McIntosh Preamplifier. When the Preamplifier is switched On, a (5-15VDC) signal operates the power



Figure 24

relay in the MC1.25KW. The MC1.25KW also has a remote Power Control Out Jack. The Power Control signal from this jack is delayed by a fraction of a second so that the turn on power surge of the next power amplifier occurs at a later time. This helps prevent power circuit overload that could trip circuit breakers or blow fuses, a very important feature in a high power Home Theater System employing three or more MC1.25KW Power Amplifiers.



Figure 25

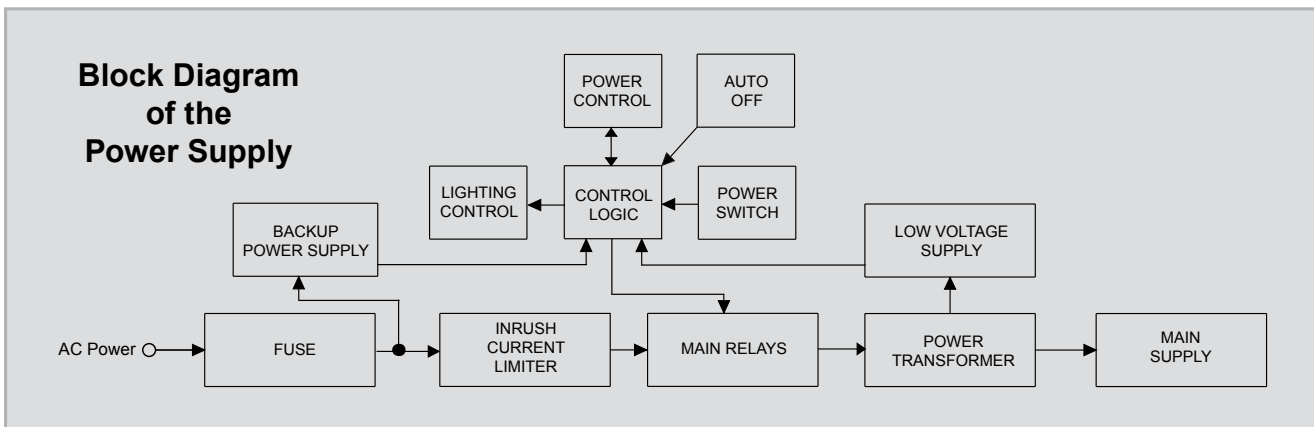

Figure 23



Power Amplifier Specifications

Power Output

Minimum sine wave continuous average power output is:

- 1,200 watts into 2 ohm load
- 1,200 watts into 4 ohm load
- 1,200 watts into 8 ohm load

Output Load Impedance

2, 4 or 8 ohms

Rated Power Band

20Hz to 20,000Hz

Total Harmonic Distortion

0.005% maximum harmonic distortion at any power level from 250 milliwatts to rated power, 20Hz to 20,000Hz

Dynamic Headroom

2.2dB

Frequency Response

- +0, -0.25dB from 20Hz to 20,000Hz
- +0, -3dB from 10Hz to 100,000Hz

Input Sensitivity (for rated output)

- 4.8 Volt Balanced
- 2.4 Volt Unbalanced

Signal To Noise Ratio (A-Weighted)

- 124dB below rated output, Balanced
- 120dB below rated output, Unbalanced

Intermodulation Distortion

0.005% maximum, if the instantaneous peak power output does not exceed twice the rated power output for any combination of frequencies from 20Hz to 20,000Hz

Wide Band Damping Factor

Greater than 40

Input Impedance

10,000 ohms

Power Guard

Less than 2% THD with up to 14dB overdrive at 1,000Hz

Power Control Input

5-15VDC, less than 1mA

Power Control Output

12VDC, 50mA maximum total
Output is delayed 0.2 seconds from turn On

General Specifications

Power Requirements

- 100 Volts, 50/60Hz at 15 Amps
- 110 Volts, 50/60Hz at 12.5 Amps
- 120 Volts, 50/60Hz at 12 Amps
- 220 Volts, 50/60Hz at 7.5 Amps
- 230 Volts, 50/60Hz at 6.5 Amps
- 240 Volts, 50/60Hz at 6.5 Amps
- Standby: 0.5 watts

Note: Refer to the rear panel of the MCI.25KW for the correct voltage.

Overall Dimensions

- Width is 17-3/4 inches (45.09cm)
- Height is 12-5/16 inches (31.27cm) including feet
- Depth is 22 inches (55.88cm) including the Front Panel and Cables

Weight

158 pounds (71.7 kg) net, 184 pounds (83.4 kg) in shipping carton

Shipping Carton Dimensions

- Width is 31 inches (78.74cm)
- Depth is 28 inches (71.12cm)
- Height is 17-1/4 inches (43.82cm)

Packing Instructions

In the event it is necessary to repack the equipment for shipment, the equipment must be packed exactly as shown below. It is very important that the four feet are attached to the bottom of the equipment. This will ensure the proper equipment location on the bottom foam pad. Failure to do this will result in shipping damage.

Use the original shipping carton and interior parts only if they are all in good serviceable condition. If a shipping carton or any of the interior part(s) are needed, please call or write Customer Service Department of McIntosh Laboratory. Refer to page 2. Please see the Part List for the correct part numbers.

Quantity	Part Number	Description
1	034105	Shipping carton top
1	034104	Shipping carton bottom
2	034439	Foam Pad (top and bottom)
3	034441	Foam Ring
4	400159	10-32 x 3/4 inch screw
4	218085	Feet

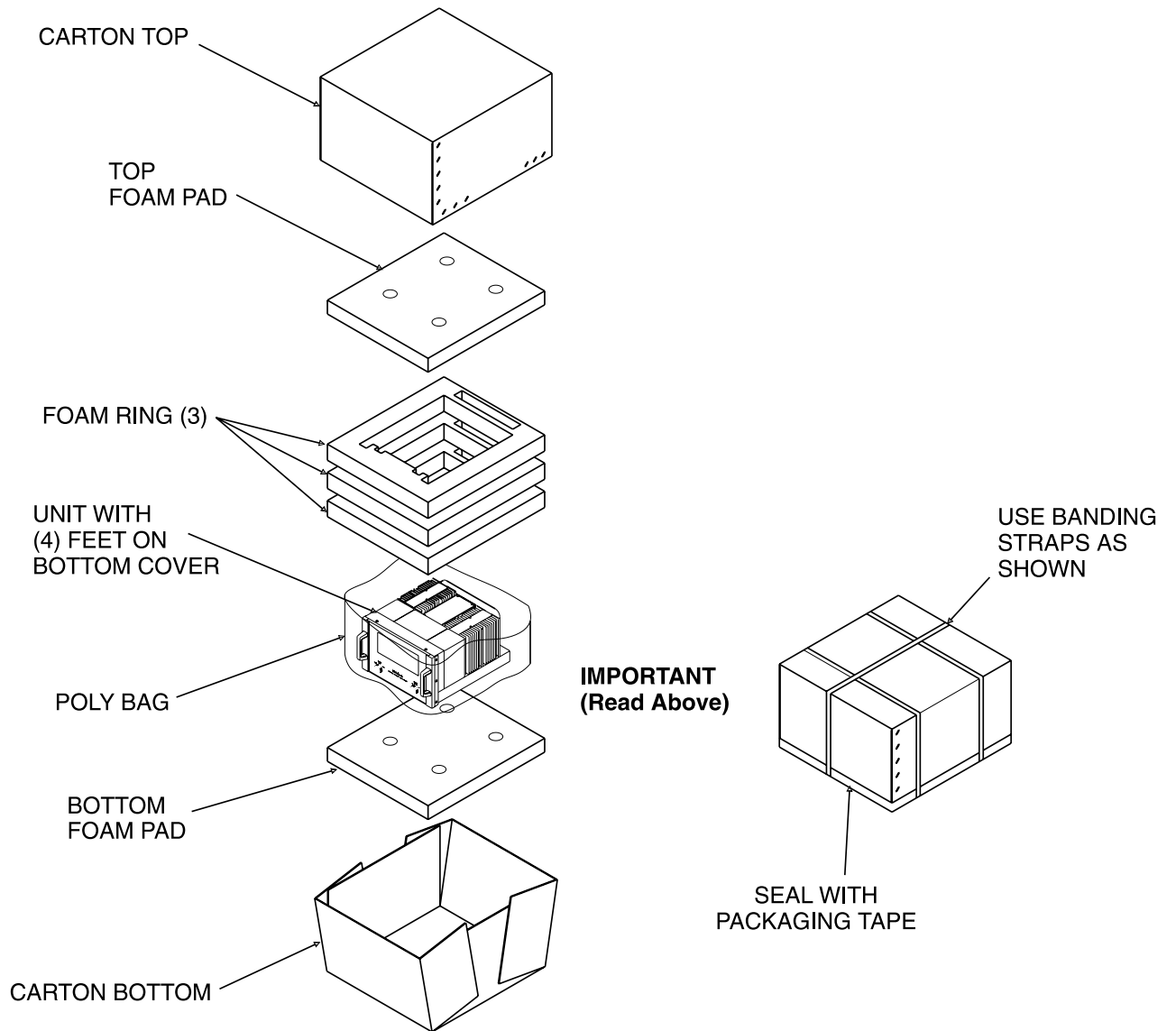



McIntosh Laboratory, Inc.
2 Chambers Street
Binghamton, NY 13903
www.mcintoshlabs.com

The continuous improvement of its products is the policy of McIntosh Laboratory Incorporated who reserve the right to improve design without notice.
Printed in the U.S.A.