



SP25 Prisma User Guide

CONTENTS

Safety information

Welcome!

Getting started

Back panel connections

Using the PRISMA remote

Using the SP25

Source options

Configuring the SP25

Setting up sources

Speaker configurations

Setting up speakers

Dirac Live

Other settings

Technical specification

Additional information



SP25 Prisma User Guide

CONTENTS

Safety information

Welcome!

Getting started

Back panel connections

Using the PRISMA remote

Using the SP25

Source options

Configuring the SP25

Setting up sources

Speaker configurations

Setting up speakers

Dirac Live

Other settings

Technical specification

Additional information

SAFETY INFORMATION

CAUTION

TO REDUCE THE RISK OF FIRE, REPLACE WITH THE SAME TYPE AND RATING OF FUSE.

ATTENTION

UTILISER UN FUSIBLE DE RECHANGE MÊME TYPE.

Safety compliance

This product has been designed to meet the IEC 60065 international electrical safety standard.

CAUTION

RISK OF ELECTRIC SHOCK DO NOT OPEN

ATTENTION

RISQUE DE CHOC ELECTRIQUE NE PAS OUVRIR



The lightning flash with an arrowhead symbol within an equilateral triangle, is intended to alert the user to the presence of uninsulated 'dangerous voltage' within the product's enclosure that may be of sufficient magnitude to constitute a risk of electric shock to persons.



The exclamation point within an equilateral triangle is intended to alert the user to the presence of important operating and maintenance (servicing) instructions in the literature accompanying the product.

CAUTION: To reduce the risk of electrical shock do not remove cover (or back). No user serviceable parts inside. Refer servicing to qualified service personnel.

WARNING: To reduce the risk of fire or electrical shock, do not expose this apparatus to rain or moisture.

CAUTION: In Canada and the USA, to prevent electric shock, match the wide blade of the plug to the wide slot in the socket and insert the plug fully into the socket.

This product is designed and manufactured to meet strict quality and safety standards. However, you should be aware of the following installation and operation precautions.

1. Take heed of warnings & instructions

You should read all the safety and operating instructions before operating this appliance. Retain this handbook for future reference and adhere to all warnings in the handbook or on the appliance.

2. Water and moisture

The presence of electricity near water can be dangerous. Do not use the appliance near water – for example next to a bathtub, washbowl, kitchen sink, in a wet basement or

near a swimming pool, etc.

3. Object or liquid entry

Take care that objects do not fall and liquids are not spilled into the enclosure through any openings. Liquid-filled objects such as vases should not be placed on the equipment.

4. Ventilation

Do not place the equipment on a bed, sofa, rug or similar soft surface, or in an enclosed bookcase or cabinet, since ventilation may be impeded. We recommend a minimum distance of 50mm around the sides and top of the appliance to provide adequate ventilation.

5. Heat

Locate the appliance away from naked flames or heat producing equipment such as radiators, stoves or other appliances (including other amplifiers) that produce heat.

6. Climate

The appliance has been designed for use in moderate climates.

7. Racks and stands

Only use a rack or stand that is recommended for use with audio equipment. If the equipment is on a portable rack it should be moved with great care, to avoid overturning the combination.

8. Cleaning

Unplug the unit from the mains supply before cleaning.

The case should normally only require a wipe with a soft, damp, lint-free cloth. Do not use paint thinners or other chemical solvents for cleaning.

We do not advise the use of furniture cleaning sprays or polishes as they can cause indelible white marks if the unit is subsequently wiped with a damp cloth.

9. Power sources

This appliance must be connected to a mains socket outlet using the supplied power cord. To disconnect this apparatus from power, you must disconnect the power cord. Make sure the power cord is always easily accessible.

Only connect the appliance to a power supply of the type described in the operating

instructions or as marked on the appliance.

This is a Class 1 device and **must** be earthed.

The power switch is a single-pole switch. When the switch is in the “Off” position, the appliance is not completely disconnected from the main power.

10. Power-cord protection

Power supply cords should be routed so that they are not likely to be walked on or pinched by items placed upon or against them, paying particular attention to cords and plugs, and the point where they exit from the appliance.

11. Grounding

Ensure that the grounding means of the appliance is not defeated.

12. Power lines

Locate any outdoor antenna/aerial away from power lines.

13. Non-use periods

If the unit has a stand-by function, a small amount of current will continue to flow into the equipment in this mode. Unplug the power cord of the appliance from the outlet if left unused for a long period of time.

14. Abnormal smell

If an abnormal smell or smoke is detected from the appliance, turn the power off immediately and unplug the unit from the wall outlet. Contact your dealer immediately.

15. Servicing

You should not attempt to service the appliance beyond that described in this handbook. All other servicing should be referred to qualified service personnel.

16. Damage requiring service

The appliance should be serviced by qualified service personnel when:

- A. the power-supply cord or the plug has been damaged, or
- B. objects have fallen, or liquid has spilled into the appliance, or
- C. the appliance has been exposed to rain, or
- D. the appliance does not appear to operate normally or exhibits a marked change in

performance, or

E. the appliance has been dropped or the enclosure damaged.

2.4G and 5G FCC Statements

This device complies with Part 15 of the FCC Rules. Operation is subject to the following two conditions:

1. This device may not cause harmful interference, and
2. This device must accept any interference received, including interference that may cause undesired operation.

Cet appareil est conforme à la section 15 des réglementations de la FCC. Le fonctionnement de l'appareil est sujet aux deux conditions suivantes :

1. cet appareil ne doit pas provoquer d'interférences néfastes, et
2. cet appareil doit tolérer les interférences reçues, y compris celles qui risquent de provoquer un fonctionnement indésirable.

Note: This product has been tested and found to comply with the limits for a Class B digital device, pursuant to Part 15 of the FCC Rules. These limits are designed to provide reasonable protection against harmful interference in a residential installation. This product generates, uses, and can radiate radio frequency energy and, if not installed and used in accordance with the instructions, may cause harmful interference to radio communications. However, there is no guarantee that interference will not occur in a particular installation. If this product does cause harmful interference to radio or television reception, which can be determined by turning the equipment off and on, the user is encouraged to try to correct the interference by one or more of the following measures:

- Reorient or relocate the receiving antenna.
- Increase the separation between the equipment and receiver.
- Connect the equipment into an outlet on a circuit different from that to which the receiver is connected.
- Consult the dealer or an experienced radio/TV technician for help.

Please take attention that changes or modification not expressly approved by the party responsible for compliance could void the user's authority to operate the equipment.

This equipment should be installed and operated with a minimum distance 20cm between the radiator and your body.

Cet équipement doit être installé et utilisé à une distance minimale de 20 cm entre le radiateur et votre corps.

This device complies with Industry Canada licence-exempt RSS standard(s). Operation is subject to the following two conditions:

1. this device may not cause interference, and
2. this device must accept any interference, including interference that may cause undesired operation of the device.

Le présent appareil est conforme aux CNR d'Industrie Canada applicables aux appareils radioexempts de licence. L'exploitation est autorisée aux deux conditions suivantes :

1. l'appareil ne doit pas produire de brouillage, et
2. l'utilisateur de l'appareil doit accepter tout brouillage radioélectrique subi, même si le brouillage est susceptible d'en compromettre le fonctionnement.

Under Industry Canada regulations, this radio transmitter may only operate using an antenna of a type and maximum (or lesser) gain approved for the transmitter by Industry Canada. To reduce potential radio interference to other users, the antenna type and its gain should be so chosen that the equivalent isotropically radiated power (e.i.r.p.) is not more than that necessary for successful communication.

Conformément à la réglementation d'Industrie Canada, le présent émetteur radio peut fonctionner avec une antenne d'un type et d'un gain maximal (ou inférieur) approuvé pour l'émetteur par Industrie Canada. Dans le but de réduire les risques de brouillage radioélectrique à l'intention des autres utilisateurs, il faut choisir le type d'antenne et son gain de sorte que la puissance isotrope rayonnée équivalente (p.i.r.e.) ne dépasse pas l'intensité nécessaire à l'établissement d'une communication satisfaisante.



The CE symbol indicates that this Primare product complies with the EMC (Electromagnetic Compatibility) and LVD (Low Voltage Directive) standards of the European Community.

The WEEE symbol indicates this Primare product complies with the European Parliament and Council Directive 2002/96/EC concerning Waste Electrical and Electronic Equipment (WEEE). This product must be appropriately recycled or processed in accordance with these directives. Consult your local waste disposal authority for guidance.

The RoHS symbol indicates that Primare products are designed and manufactured to comply with the Restriction of Hazardous Substances (RoHS) as stated in the European Parliament and Council Directive 2002/95/EC.

Copyright and acknowledgments

Copyright © 2024 Primare AB.
All rights reserved.

Primare AB
Limstensgatan 7
21616 Limhamn
Sweden

<https://primare.net>

Issue: SP25Prisma/2

The information in this guide is believed to be correct as of the date of publication. However, our policy is one of continuous development and so the information is subject to change without notice, and does not represent a commitment on the part of Primare AB.

Dolby, Dolby Atmos, and the double-D symbol are registered trademarks of Dolby Laboratories Licensing Corporation. Manufactured under license from Dolby Laboratories. Confidential unpublished works. Copyright © 2012-2021 Dolby Laboratories. All rights reserved.

For DTS patents, see <http://patents.dts.com>. Manufactured under license from DTS Licensing Limited. DTS, the Symbol, & DTS and the Symbol together, DTS:X, and the DTS:X logo are registered trademarks and/or trademarks of DTS, Inc. in the United States and/or other countries. © DTS, Inc. All Rights Reserved.

Primare is a trademark of Primare AB.

This guide was produced by
Human-Computer Interface Ltd.
<http://www.interface.co.uk>



SP25 Prisma User Guide

CONTENTS

Safety information

Welcome!

Getting started

Back panel connections

Using the PRISMA remote

Using the SP25

Source options

Configuring the SP25

Setting up sources

Speaker configurations

Setting up speakers

Dirac Live

Other settings

Technical specification

Additional information

WELCOME!

Congratulations on selecting your new SP25 Prisma Home Cinema Integrated Amplifier.

The SP25 Prisma is a multi-channel integrated preamplifier and processor designed for both cinephile and audiophile, composed of carefully considered and crafted features

and functionality to provide the best home cinema experience for the greatest number of people.

This user guide describes the features and explains how to set up the SP25 for the best sound quality and ease of operation in order to allow for the most enjoyable reproduction of sound from all your sources.



For additional support and assistance please contact your local authorized Primare dealer, or visit our website at www.primare.net.



SP25 Prisma User Guide

CONTENTS

Safety information

Welcome!

Getting started

Back panel connections

Using the PRISMA remote

Using the SP25

Source options

Configuring the SP25

Setting up sources

Speaker configurations

Setting up speakers

Dirac Live

Other settings

Technical specification

Additional information

GETTING STARTED

1 Unpack the SP25 Prisma

Your SP25 Prisma is supplied with the following components:

- Mains cable
- Antennas for Bluetooth and Wi-Fi
- PRISMA remote, including two AAA cells
- AC polarity pen, including two AAA cells
- Microphone for Dirac Live calibration

If any of these items are missing please contact your supplier. We recommend you retain the packaging in case you need to transport the unit at a later date.

Note that the SP25 is supplied with a protective film on the display glass. Remove the film for a clearer display.

2 Connect a display

Connect the MAIN HDMI output from your SP25 Prisma to your television or display HDMI input, noting that OSD (On-Screen-Display) is not available with the AUX HDMI output.

If your television includes an HDMI tuner output you can use the SP25 to perform switching between the television tuner and your other video sources such as DVD or Blu-Ray. In this case connect the television tuner output to the HDMI input corresponding to your TV source. By default preset 1 uses the HDMI 1 input and Preset 2 uses the HDMI 2 input, but you can reassign these.

If your television does not provide a tuner output you will need to switch the television between its internal tuner and the external video input.

3 Connect amplifiers and speakers

The SP25 Prisma provides line-level outputs to drive up to 15 amplifier channels and loudspeakers in variety of surround system configurations: Front 1 Left and Right, Front 2 Left and Right, Centre, Surround, Surround Back, Height Front, Height Back, and two Subwoofers.

The SP25 audio processing supports a wide range of configurations, including:

- 5.1.4, 7.1.2, and 7.1.4 configurations.
- A 5.1.2 configuration with bi-amped front left/right channels.

For full details of how to connect up the alternative surround systems see [Speaker configurations](#).

- Connect the analog outputs to the appropriate amplifiers and loudspeakers in your system.

If your system includes one or more subwoofers:

- Connect the SUB 1 and SUB 2 analog outputs to the audio inputs of the subwoofers.

You can also connect a headphone amplifier for headphone listening; see [Headphone Settings](#).

4 Connect audio inputs

You can connect five analog sources, one coax digital source, and two optical digital sources, as well as one USB-B digital input source to the inputs on the back panel.

Analog sources

- Connect analog sources to A1 to A5, using high quality RCA cables.

Alternatively you can connect a 7.1 source to analog inputs A1 to A4 using four pairs of RCA cables.

Digital sources

- Connect a digital coax source to D1, using a digital RCA cable.
- Connect digital optical sources to the digital optical inputs D2 and D3 using optical cables.

You can also connect a PC or Mac to the USB-B input to use the SP25 as an audio output device for your computer.

Using a drive or music server

You can play music from a USB flash drive connected to the USB-A input, or stream music from a network-connected music server. For more information see [Source options: Playing music from a drive or music server](#).

Streaming

You can stream music wirelessly to the SP25 from a mobile phone, tablet, computer, or other Prisma product via Bluetooth or Wi-Fi, or via a wired Ethernet connection. For more information see [Source options: Streaming music from a phone, tablet, or PC](#).

5 Connect video inputs

You can connect up to four audio/video sources to the four HDMI inputs, by connecting HDMI cables from four audio/video sources to HDMI 1 to HDMI 4.

6 Connect the antennae

- Connect the two antennae supplied with the SP25 to the ANT 1 and ANT 2 sockets

on the back panel, and position the two antennae at a slight angle from the vertical. The antennae are used for Bluetooth and Wi-Fi connectivity.

7 Connect power

- Plug one end of the mains cable supplied with the SP25 into the power connector on the back panel and connect the other end to a wall socket.

If this cable is not suitable for your power outlets please contact your supplier for an alternative cable.

Note: See [Phase](#) for information about ensuring that the AC cable plug orientation is correct to get the best sound from your SP25.



WARNING: Always disconnect the SP25 from the mains power before connecting or disconnecting any cables.

- Switch on the SP25, using the switch on the back panel.

To switch on from standby

- Press  on the front panel or PRISMA remote.

The display shows:

PRIMARE

8 Configure the speakers

Before using the SP25 Prisma you need to configure it to specify the combination of amplifiers and speakers you have in your surround system. For more information see [Setting up speakers](#).

You then need to set up the speaker distances and speaker levels, to ensure that the sound image is correctly focused at the listening position. For more information see [Setting up speakers: Distance](#) and [Setting up speakers: Level](#).

9 Play a source

- Press the ▲ or ▼ buttons on the front panel, or the ◀ or ▶ buttons on the PRISMA remote, to select the source.
- Use the VOLUME control on the front panel or the + and – buttons on the PRISMA remote to adjust the volume.

For more information about playing sources see [Selecting a source](#).

Note: The SP25 is classified as a HiNA (high-network availability) product. If no audio

stream signal is detected for 20 minutes the unit will automatically go into network standby mode, in which the power consumption of the device is <6W. The unit will exit from network standby mode when audio streaming is detected.

10 Connect to a network with Ethernet cable

For best results we recommend connecting using an Ethernet network cable.

Connecting via an Ethernet cable

To connect via an Ethernet cable:

- Connect an Ethernet cable between your router or switch and one of the LAN ports on the back panel of the SP25.

Using an Ethernet cable connection provides immediate access to your network, and the front-panel display will show **LAN** in its lower right corner to indicate that a connection is established.

If the front panel display shows **Setup mode** make sure your Ethernet cable is connected and it has a network connection.

To take advantage of Chromecast built-in related features and functionality – such as casting, voice control, and multi-room/multi-zone configuration and control – you must configure the SP25 using the **Google Home** app, with a Google account.

- Make sure Bluetooth and Wi-Fi are enabled on your mobile device.
- Install the free **Google Home** app on your mobile device.
- Open the **Google Home** app and follow the instructions for setting up the SP25 Prisma on your network in the *Chromecast Built-in Quick Start Guide*, or the brief description below:

The **Google Home** app will display **Set up SPA25 Prisma**.

- Click **SET UP** and follow the instructions.

The front panel display will show:

Configure network

A test tone will be played and you will be prompted to select a name for your SP25 Prisma.

If you cannot hear the test sound you may need to increase the volume on your amplifier.

- Enter an appropriate name.

Once you have configured the SP25 Prisma using the **Google Home** app the **Configure network** message on the front panel display will disappear.

You will now be able to stream music to your SP25 Prisma.

To disconnect from the network

- Remove the Ethernet cable.

11 Connect to a Wi-Fi network

Make sure there is no Ethernet cable inserted to any of the LAN ports. When the SP25 Prisma is ready to be set up via Wi-Fi the front-panel display will show:



Setup mode

You can connect to Wi-Fi either by using the iOS **AirPlay speaker setup**, the Android **Prisma** app, or the **Google Home** app.

To take advantage of Chromecast built-in related features and functionality – such as casting, voice control, and multi-room/multi-zone configuration and control – you must configure the SP25 using the **Google Home** app, with a Google account.

AirPlay speaker setup

- Go to the **Wi-Fi** menu under **Settings** on your iOS device.
- Select the Prisma model you want to set up under **SET UP NEW AIRPLAY SPEAKER** at the bottom of the list.
- Select the Wi-Fi network you want your SP25 to connect to and select **Next**.
- Follow the instructions on the screen to complete the setup.

Prisma Android app

- Open the Android **Prisma** app and follow the instructions at the link in the discovery page.

Google Home app

- Make sure Bluetooth and Wi-Fi are enabled on your mobile device.
- Install the free **Google Home** app on your mobile device.
- Open the **Google Home** app and follow the instructions for setting up the SP25 Prisma on your network in the *Chromecast Built-in Quick Start Guide*, or the brief description below:

The **Google Home** app will display **Set up SPA25 Prisma**.

- Click **SET UP** and follow the instructions.

The front panel display will show:

Configure network

A test tone will be played and you will be prompted to select a name for your SP25.

If you cannot hear the test sound you may need to increase the volume on your amplifier.

- Enter an appropriate name.
- Select the Wi-Fi network your SP25 should connect to.

Once you have configured the SP25 using the **Google Home** app the **Configure network** message will disappear from the front-panel display.

You will now be able to stream music to your SP25.

To disconnect from the Wi-Fi network

Either:

- Select **Wi-Fi settings** for the SP25 in the **Google Home** app.
- Select **Forget this network**.

Or:

- Reset the SP25 to its factory defaults; see [Factory reset](#).

12 Download the Prisma app

To view and change the SP25 Prisma settings you need the Primare Prisma app, which is available for free download on iOS devices from the Apple App Store and on Android devices from the Google Play Store.

In either case search for **Primare Prisma** to find the app.



SP25 Prisma User Guide

CONTENTS

Safety information

Welcome!

Getting started

Back panel connections

Using the PRISMA remote

Using the SP25

Source options

Configuring the SP25

Setting up sources

Speaker configurations

Setting up speakers

Dirac Live

Other settings

Technical specification

Additional information

BACK PANEL CONNECTIONS

The following diagram explains the function of each of the connectors on the back panel:

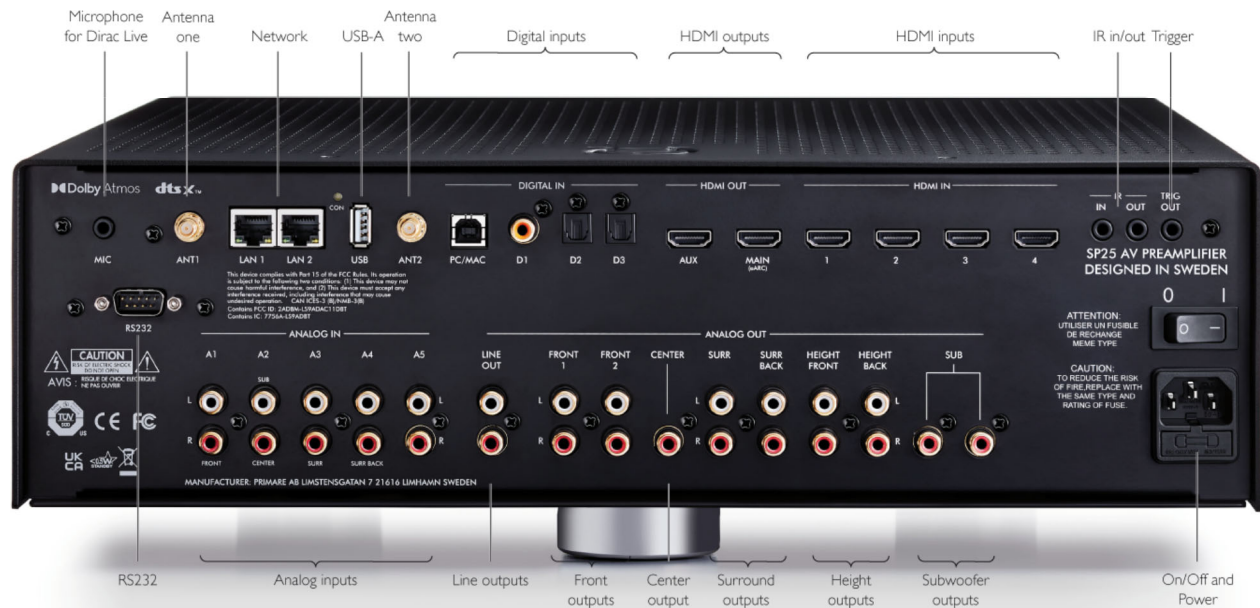

[Click to display a larger version.](#)



SP25 Prisma User Guide

CONTENTS

- Safety information
- Welcome!
- Getting started
- Back panel connections
- Using the PRISMA remote
- Using the SP25
- Source options
- Configuring the SP25
- Setting up sources
- Speaker configurations
- Setting up speakers
- Dirac Live
- Other settings
- Technical specification
- Additional information

USING THE PRISMA REMOTE

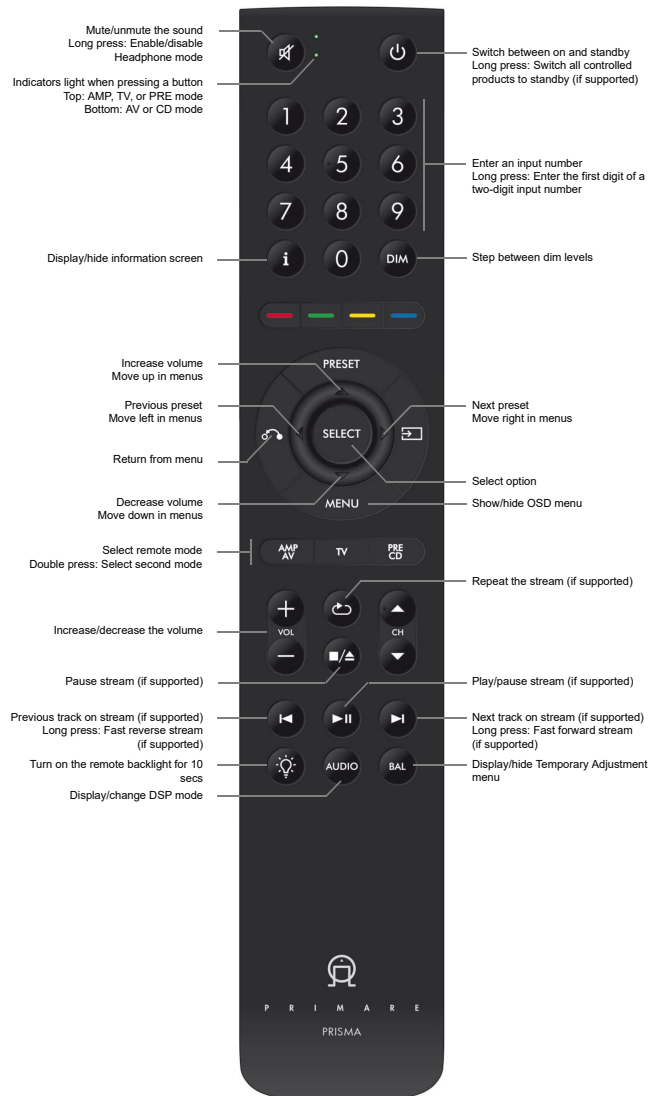

Fitting the batteries

The PRISMA remote is powered by two LR03 batteries, also known as AAA batteries. Before using the remote you need to fit the two batteries supplied with the remote.

- Press slightly on the top of the battery compartment on the back of the remote:



- Slide the back cover parallel to the case towards the bottom of the remote and remove it:



Do not attempt to use a metal object to open the cover, as you may scratch the case.

- Insert the two batteries, observing the correct polarity indicated by the '+' signs on the inside of each battery holder:

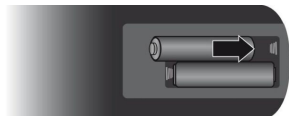

- Replace the back cover by sliding it towards the middle of the remote, until it clicks into place.

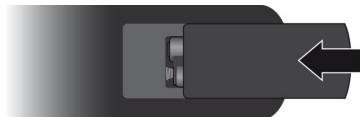

The batteries should last for about a year with normal use.

General features

The following features are available for any product you are controlling.

For details of the individual functions available for each product refer to the Prisma Remote diagram for that product; see [Prisma Remote Product Support](#).

Backlight

The PRISMA remote has a backlight, to allow you to see the keys in a dimly lit or dark room.

To turn on the backlight:

- Press the LIGHT button.

The light will stay on until no key has been pressed for ten seconds.

Long press

To select most functions you simply press the appropriate key.

Some alternate functions are available by a long press on a key of about half a second.

Putting products to standby

Pressing the STANDBY button puts the product you are currently controlling to standby, or turns it on from standby.

Giving a long press on the STANDBY button puts all controlled products to standby, including the TV.

Entering numbers

To enter a single digit number, such as an input number on a preamplifier, or a track number on a CD, you simply press the appropriate number key.

Entering two-digit numbers

If you need to enter a two-digit number, on most products you can do this as follows:

- Long press on a digit key to enter the first digit.
- Press a digit key to enter the second digit.



SP25 Prisma User Guide

CONTENTS

Safety information

Welcome!

Getting started

Back panel connections

Using the PRISMA remote

Using the SP25

Source options

Configuring the SP25

Setting up sources

Speaker configurations

Setting up speakers

Dirac Live

Other settings

Technical specification

Additional information

USING THE SP25

Front panel controls

Almost all the functions of the SP25 Prisma Multi-Channel Processor can be accessed using the front panel controls, and information about its operation is displayed on the front panel display:

Standby

Switches the SP25 to standby, or switches it on from standby.

Long press the standby button will show the main firmware version in the OLED display.

Keep the button pressed for 10 seconds will perform a factory reset.

and

Step between presets.

OSD (on-screen-display) settings

Pressing



and



simultaneously displays the settings menus or exits from the menus.

In the settings menus:

Pressing



or



steps between the settings.

Holding down



selects a setting or saves an edited setting.

Holding down



navigates back or cancels editing a setting.



VOLUME

Adjusts the volume.

Changing the volume

The SP25 allows you to vary the volume from 0 (silence) to 99 (maximum), although by default the maximum volume is set at 70.

To change the volume

- Turn the VOLUME selector on the front panel, press + or – buttons or the  or  buttons on the PRISMA remote, or press + or – in the Prisma app.

The current volume setting is shown on the front panel; for example:

VOL 28

To mute the sound

- Press  on the PRISMA remote.

To restore the sound to its original volume

- Press  again on the PRISMA remote, or adjust the volume.

Selecting a source

The SP25 Prisma allows you to define up to 17 presets. Each preset can use one of the analogue or digital audio inputs, and any preset can be combined with one of the HDMI inputs. Alternatively, a multi-channel source can be defined using analog inputs A1 to A4.

When the SP25 Prisma is first supplied the eight standard presets shown in the following table are already set up for you:

Preset	Alias	Description
1	HDMI 1	Video and digital audio on HDMI 1 input.
2	HDMI 2	Video and digital audio on HDMI 2 input.
3	HDMI ARC	Audio on HDMI Main (ARC)
4	A1	Analogue audio on A1 input (RCA connectors).
5	A2	Analogue audio on A2 input (RCA connectors).
6	D1 Coaxial	Digital audio on D1 input (RCA connector).
7	D2 Optical	Digital audio on D2 input (Optical connector).
8	PC/MAC	Digital audio on PC/MAC input (USB-B connector).
17	Prisma	Digital audio from network sources.

By default only presets 1 and 2 include video.

To step between presets

- Press the ▲ or ▼ buttons on the front panel, or the ◀ or ▶ buttons on the PRISMA remote, to step between presets.

The display shows the current preset alias; for example:

HDMI 1

To select a preset directly

- Press the number of the preset on the PRISMA remote.

To select a preset number greater than 9, long-press the first digit and then press the second digit.

You can disable any preset you don't need. You can also change any preset to use different inputs, or configure your own presets with any name you choose and using any particular inputs as appropriate for the preset.

On Screen Display

An on-screen display is overlaid on your video image when you adjust settings on the SP25:



This shows:

- The current preset alias, and the signal.
- The video and audio inputs used by the preset.
- The volume.

You can choose how long the OSD stays on the display, and whether the background is transparent; see [Setting up Sources: Video Settings](#).

Changing the display brightness

To change the front panel display brightness

- Press the **DIM** button on the PRISMA remote to step through the three brightness levels and blank.

If you blank the display it will be restored briefly when you operate any control.

The display automatically dims after ten minutes; you can adjust this delay in the settings menus; see [Other Settings: General Settings](#).

Selecting the DSP mode

The DSP mode determines how the audio signal is post-processed.

The SP25 lets you choose an appropriate DSP mode for each source preset. For example, Dolby Surround may be appropriate for movies, but Bypass may be more appropriate for classical music.

To change the DSP mode

- Press **AUDIO** on the PRISMA remote.

The on-screen display shows the DSP Mode menu with the current DSP mode highlighted:

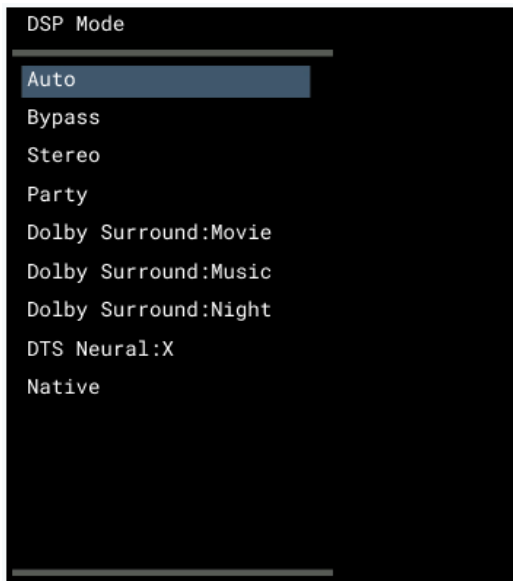

The options available depend on the source you are listening to.

- Press ▲ or ▼ on the PRISMA remote to select the new DSP mode and press **SELECT** to select it.

Note that this adjustment is temporary, and the default setting is restored if you change preset or enter standby. If you want to make a permanent change to a preset, edit its configuration using the **Preset Settings** menu; see [Setting up sources: Preset Settings](#).

Option	Description
Auto	Incoming digital signals will be decoded by DSP. Note: Dolby and DTS bitstream signals may be upmixed or downmixed depending upon format and speaker configuration. Incoming analog signals will go via DSP to allow for distance and bass management settings.
Bypass	Incoming digital signals go outside DSP directly to the DAC. Incoming analog signals go directly to volume circuitry. Bypass mode is required for DSD and DoP signals to be played. No bass management can be applied. Bypass is not supported for HDMI sources.
Stereo	Multi-channel signals will be downmixed to 2-channel audio. Analog audio will go via DSP to allow for distance and bass management settings.
Party	The left and right front channels are played to all enabled speakers. Center speaker will output a mono mix of left and right front

channels.

**Dolby Surround
Movie**

Incoming signals will be up-mixed to all enabled speakers, using an audio processing profile optimized for movies.
This mode cannot be applied to DTS signals.

**Dolby Surround
Music**

Up-mixes incoming signals to all enabled speakers, using an audio processing profile optimized for music.
This mode cannot be applied to DTS signals.

**Dolby Surround
Night**

Incoming signals will be up-mixed to all enabled speakers, using an audio processing profile optimized for quieter listening.
This mode cannot be applied to DTS signals.

DTS Neural:X

Incoming signals will be up-mixed to all enabled speakers.
This mode cannot be applied to Dolby signals.

**Native
(New feature)**

Incoming Dolby bitstream signals will be kept native and decoded by DSP. (Dolby up- or down-mixing will not take place)

Changing the levels

You can independently change the balance, center level, surround level, surround back level, and subwoofer level to alter the balance of sound in your surround system.

Changing the balance alters the level of both the left and right main loudspeakers to shift the position of the stereo image, keeping the overall level of the sound the same. The other adjustments change the level of the corresponding speaker(s) without affecting the remaining speakers in the surround system.

To change levels

- Press **BAL** on the PRISMA remote.

The display shows the first setting:



AV Delay:0ms

- Press ▲ or ▼ on the PRISMA remote to step between levels.
- Press ◀ or ▶ on the PRISMA remote to adjust the current level.

Note that these adjustments are temporary, and the default setting is restored if you change preset. If you want to make a permanent change to a preset, edit its configuration using the **Preset Settings** menu; see [Setting up sources](#).

The settings are shown in the following table:

Level	Range	Description
-------	-------	-------------

AV Delay	0ms to 200ms	Delay audio to match video (lipsync).
FL	-12.0dB to +12.0dB	Front left level.
C	-12.0dB to +12.0dB	Centre level.
FR	-12.0dB to +12.0dB	Front right level.
SR	-12.0dB to +12.0dB	Side right level.
SBR	-12.0dB to +12.0dB	Surround back right level.
SBL	-12.0dB to +12.0dB	Surround back left level.
SL	-12.0dB to +12.0dB	Side left level.
Sub	-12.0dB to +12.0dB	Subwoofer level.
HL	-12.0dB to +12.0dB	Height left level.
HR	-12.0dB to +12.0dB	Height right level.
HRL	-12.0dB to +12.0dB	Height rear left level.
HRL	-12.0dB to +12.0dB	Height rear right level.

The level adjustments go clockwise around the loudspeakers in your surround system, starting with the front left speaker.



SP25 Prisma User Guide

CONTENTS

Safety information

Welcome!

Getting started

Back panel connections

Using the PRISMA remote

Using the SP25

Source options

Configuring the SP25

Setting up sources

Speaker configurations

Setting up speakers

Dirac Live

Other settings

Technical specification

Additional information

SOURCE OPTIONS

Connecting direct sources

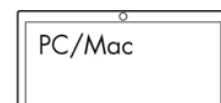

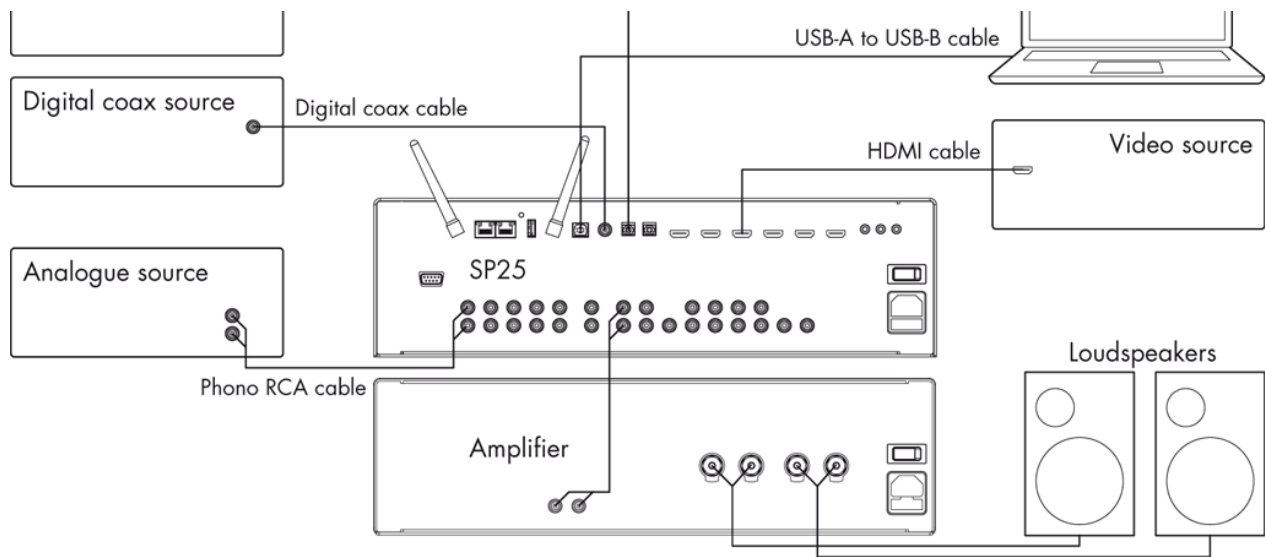

[Click to display a larger version.](#)

These methods of playing music from the SP25 involve connecting the source to the SP25 via a cable, and don't require Wi-Fi, Ethernet, or Bluetooth.

To play music from a source

- Connect the source via a suitable cable:

Source	Cable
Analogue	Phono RCA cable
Digital optical	Digital optical cable
Digital	Digital coax cable

- Select the source from the front panel, or using the remote control.

If you have a phone or tablet on the same Wi-Fi network as the SP25 you can also use the Prisma app to select and control sources.

To use the SP25 as a PC/Mac sound output device

- Connect the computer's USB port to the USB-B input on the SP25 using a USB A to USB B cable.

PC

Windows 7, 8, 8.1, or 10 (32/64-bit) is required. You need to install the Primare xmos audio driver, available on primare.net.

Macintosh

OSX 10.4 or later is recommended. No driver is required.

The SP25 will then appear as a sound output device called **SP25** in the Sound control panel (PC) or Sound system preferences panel (Macintosh).

- Set the **Audio Output** for the preset you want to use to **SP25** in the **Preset Settings** menu.
- Select **SP25** as the sound output device in the Mac Sound system preferences panel or the PC Sound control panel.

Playing music from a drive or music server

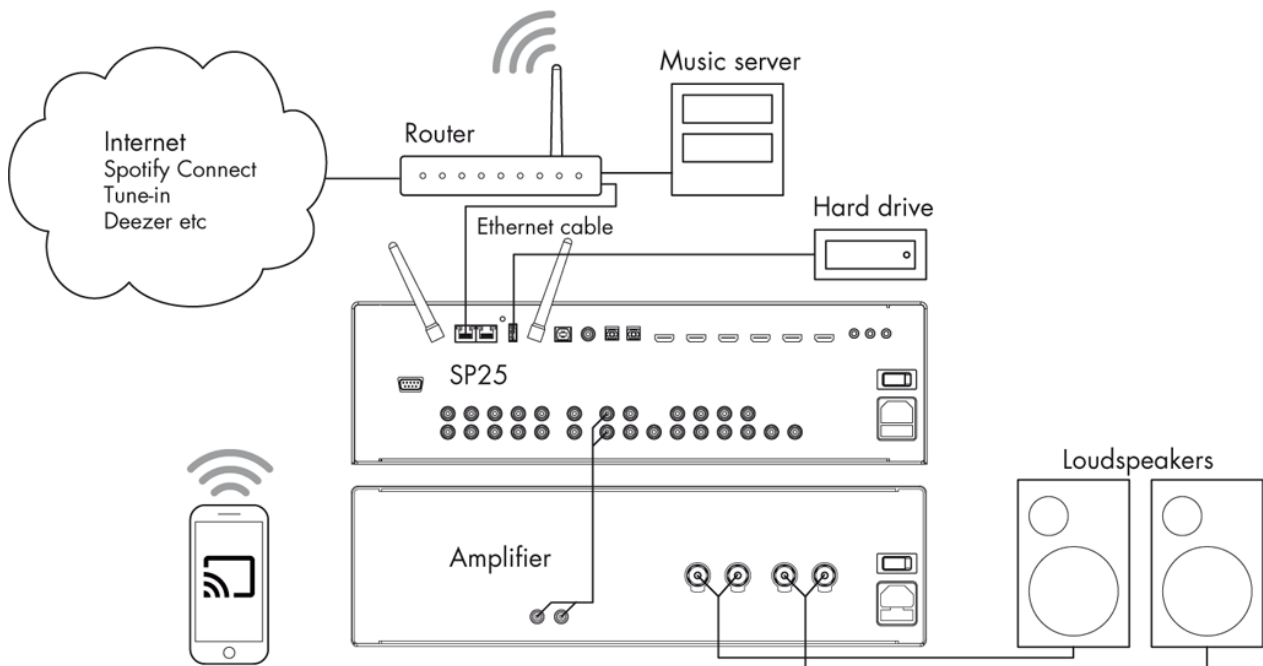

[Click to display a larger version.](#)

You can play audio files from a USB flash drive, external USB hard disk, or a network drive. These options are ideal if you already have a digital library of CDs or music files.

On a USB flash drive or USB hard disk the files can be organised into folders, giving you one way of classifying your music; eg by Artist.

On a NAS drive you have the option of running a media server program, which will catalogue your music library and give you the option of organising it in different ways; eg by Artist, Genre, Album, or Composer. One free option is MinimServer; see <http://minimserver.com/>.

To play audio files from a USB flash drive or hard drive

- Connect the USB drive to the USB-A input on the SP25.

The USB drive can contain folders and music files in any of the popular formats; see [Technical specification](#) for details.

- Use the Prisma app to browse, play, and control the music.

To play audio files from a NAS (network) drive

- Connect the NAS drive to the same network as the SP25.

The NAS drive can either contain folders and music files in any of the popular formats, or it can run a music server. See [Technical specification](#) for details of the supported file formats.

- Use the Prisma app to browse, play, and control the music.

Alternatively you can select and play music from a Mac or PC using a music server program such as JRiver or Foobar2000.

Streaming music from a phone, tablet, or PC

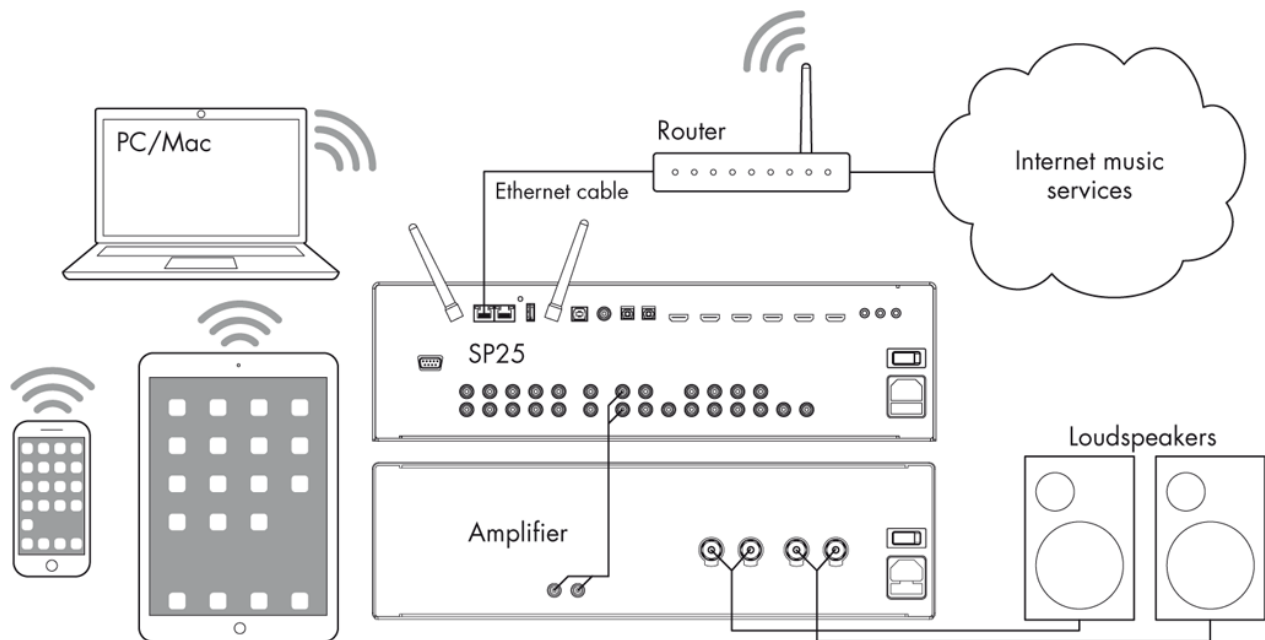

[Click to display a larger version.](#)

The SP25 can use Chromecast to connect directly to a music service that supports Chromecast, such as Spotify, Deezer, Tidal, or TuneIn Radio. The music is streamed direct to the SP25; once set up you can use your phone to make calls, or play other audio.

With a phone, tablet, or Mac/PC you can also play the audio wirelessly to the SP25,

using Bluetooth or AirPlay (iOS only), so the sound from any apps you run on your device will be played through the SP25.

Although you can stream music over Wi-Fi, for best results connect the SP25 to your home router via an Ethernet cable. If necessary, use the Google Home app to configure the network settings on your SP25.

To stream using Chromecast

The SP25 has Chromecast built-in, which means you can stream (cast) music over your network directly to the SP25 from any Chromecast supported music service, using the music service's app on your desktop or mobile device as a controller.

- Click the **Cast** button within your music service's app and select the SP25 in the device list.

To stream using AirPlay

Use AirPlay to send audio over the network from your Apple device to the SP25. AirPlay is only available on Apple devices.

To stream using Bluetooth

Use Bluetooth to send audio directly to the SP25 from your Bluetooth device using Bluetooth connection. You don't need a network to stream using Bluetooth.

To stream using Spotify Connect

The SP25 supports Spotify Connect, which means you can stream music directly to the SP25 from the Spotify music service over your network, using the Spotify app on your desktop or mobile device as a controller.

Use your phone, tablet, or computer as a remote control for Spotify. Go to <http://spotify.com/connect> to learn how.

Roon

Roon is music playback software available for a monthly subscription, and it runs on iPad, iPhone, Android tablet and phone, Mac, and Windows. The SP25 is "Roon Ready", which means that it has been certified by Roon. It is discoverable using the Roon app, and can be used as a playback device for a Roon system.

For more information see <https://primare.net/network-and-technology/roon-ready/>



SP25 Prisma User Guide

CONTENTS

Safety information

Welcome!

Getting started

Back panel connections

Using the PRISMA remote

Using the SP25

Source options

Configuring the SP25

Setting up sources

Speaker configurations

Setting up speakers

Dirac Live

Other settings

Technical specification

Additional information

CONFIGURING THE SP25

Using the menus

The **Main Menu** gives access to a series of menus which allow you to customize different aspects of the operation of the SP25 Prisma.

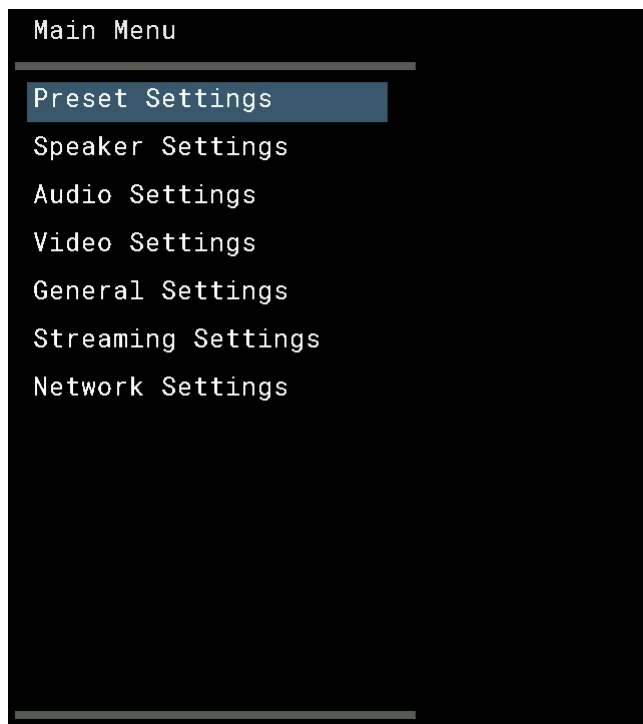

To display the Main Menu

- Press **MENU** on the PRISMA remote.

To select a menu option

- Press **▲** or **▼** on the PRISMA remote to highlight the menu option.
- Press **SELECT** on the PRISMA remote to select it.

Each of the options on the **Main Menu** display a submenu of further options.

To change a setting

- Press **▲** or **▼** on the PRISMA remote to highlight the option.
- Press **SELECT**.

A list of the alternative values for that option will be displayed, with the current one highlighted. For example:





- Press ▲ or ▼ on the PRISMA remote to select the new value.
- Press **SELECT**.

Alternatively, to return to the previous menu without changing the value press ⏪.

To exit from the current menu

- Press ⏪ on the PRISMA remote.

To exit from the setup menus

- Press **MENU** on the PRISMA remote.

Using the menus from the front panel

You can also navigate the menus from the front panel:

Remote button	Front panel equivalent
MENU	Long press ▲ and ▼
▲ and ▼	▲ and ▼
SELECT	Long press ▲



Editing an alias

- Select the **Alias** option in the **Preset Settings** or **Speaker Settings** submenus.

The following menu allows you to define the alias using the PRISMA remote:

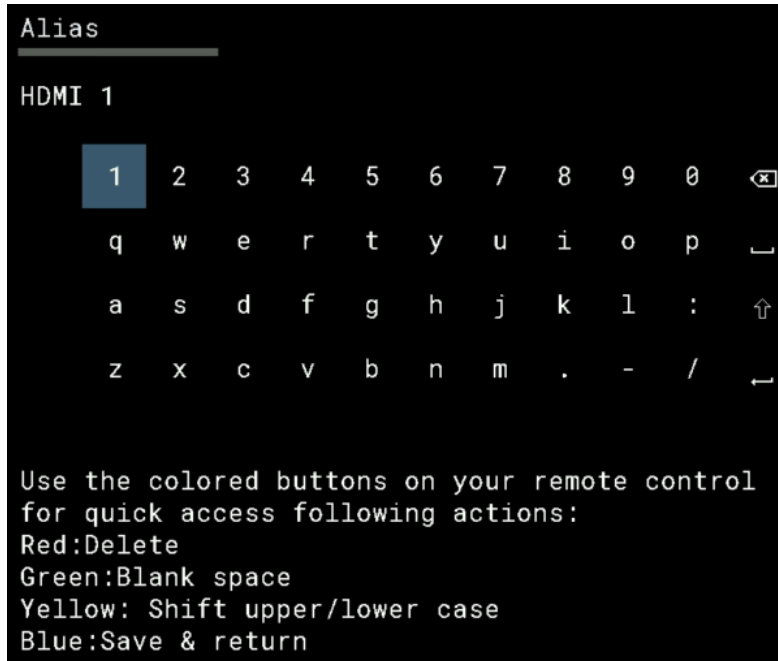

- Use the following buttons on the PRISMA remote to define the alias:

Button	Action
Arrow buttons	Highlight the character you want to enter.
SELECT	Add the highlighted character to the alias.
Red	Delete a character from the alias.
Green	Enter a space.
Yellow	Toggle between upper and lower case letters.
Blue	Save the alias and return to the previous menu.
Return	Return to the previous menu without saving the new alias.



SP25 Prisma User Guide

CONTENTS

Safety information

Welcome!

Getting started

Back panel connections

Using the PRISMA remote

Using the SP25

Source options

Configuring the SP25

Setting up sources

Speaker configurations

Setting up speakers

Dirac Live

Other settings

Technical specification

Additional information

SETTING UP SOURCES

Preset Settings

The **Preset Settings** menu allows you to customise each of the 17 available source presets:

Preset Settings	
Preset	3
Status	Enabled
Alias	A1
Video Input	None
Video Output	HDMI Main
Audio Input	A1
Audio Output	SPA25
DSP Mode	Bypass
Input Gain	0 dB
ADC Gain	0 dB
Input Balance	Centered
Volume	Variable

Choose between **Enabled** or **Disabled** to specify whether the preset is enabled.

By default presets 1 to 8 and 17 are **Enabled**, and all others are **Disabled**.

Alias

Allows you to give the source preset a memorable name; eg **Radio**. See [Configuring the SP25: Editing an alias](#) for details of entering an alias.

Video Input

Choose the video input associated with the preset, which can be **HDMI 1** to **HDMI 4**, or **None** for no video input.

Video Output

Choose the video output for the preset, from **HDMI MAIN** (the default), **HDMI AUX**, or **Both**.

Audio Input

Choose the audio input associated with the preset. The options are shown in the following table:

Option	Description
HDMI 1 to HDMI 4	Audio on the corresponding HDMI video input.
HDMI TV	Audio return channel from the TV.
D1 to D3	The digital inputs.
A1 to A5	The analog inputs.
Prisma	The Prisma streaming input.
PC/MAC	Audio from a PC or Mac connected to the USB-B input.
7.1 Bypass	Audio from a 7.1 surround source connected to A1 to A6.
None	No audio input.

Audio Output

Choose **SP25** (the default), **HDMI Out**, or **Both** for the audio output.

DSP Mode

Specifies the DSP mode for the preset. For details of the available DSP modes see [Using the SP25: Selecting the DSP mode](#).

Input Gain

Allows you to equalise the relative loudness of each source, between **-10 dB** and **+10 dB**. The default is **+0 dB**.

ADC Gain

Adjusts the gain of the analog-to-digital converter for analog sources with 1 dB steps between **-12 dB** and **+12 dB**. The default is **0 dB**. A warning message will be displayed

in the front display if the analog input level is too high.

Input Balance

Allows you to adjust the balance of the input; choose **Centered** (the default) or between **L9** (maximum left) to **R9** (maximum right).

Volume

Can be set to **Variable** (the default) or **Fixed** if you want to control the volume in the source device.

AV Delay

Allows you to delay the audio by up to **200 ms** (the default) in 10 ms steps to compensate for the delay imposed by many video displays; also known as lipsync.

Auto-Sense

Choose between: **Select** to automatically select an input containing an audio signal if the SP25 is on; **Wake&Sel** to automatically wake up the SP25 from standby, if necessary, and select an input containing an audio signal; and **OFF** (default) to disable automatic switching.

Trigger Out

Choose **ON** (the default) to activate the trigger output for this preset, or **OFF** to leave the trigger output unaffected.

Trigger Delay

Specifies a delay before the trigger output is activated, or **OFF** for no delay.

Speaker Preset

Specifies a speaker preset for this source, or **None** for no preset.

Audio Settings

The **Audio Settings** menu allows you to customise options affecting all audio outputs:



Default Volume

Allows you to set the default volume when the SP25 is switched on from standby to **Specified**, which uses the volume set in the next option, or **Last Used** (the default), which is the volume when the unit went into standby.

Specified

Specifies the volume for **Default Volume**, from 0 to 60.

Maximum Volume

Specifies the maximum volume between 0 and 99. The default is 70.

Double Bass

By default, in a system with speakers defined as **Full Range**, the subwoofer only receives the LFE signal (when available), and is not used for stereo sources.

Set **Double Bass** to **ON** to send a copy of the bass from the **Full Range** speakers to the subwoofer in addition to the LFE signal (when available).

If there are no subwoofers in the system, or there are no **Full Range** speakers, **Double Bass** has no effect.

Late Night

Reduces the loudest sounds and increases the quietest sounds for listening late at night. Choose **ON** for late night mode, or **OFF** (default) for normal mode.

Headphone Settings

Displays the **Headphone Settings** submenu, to allow you to enable Headphone Mode and configure its settings:

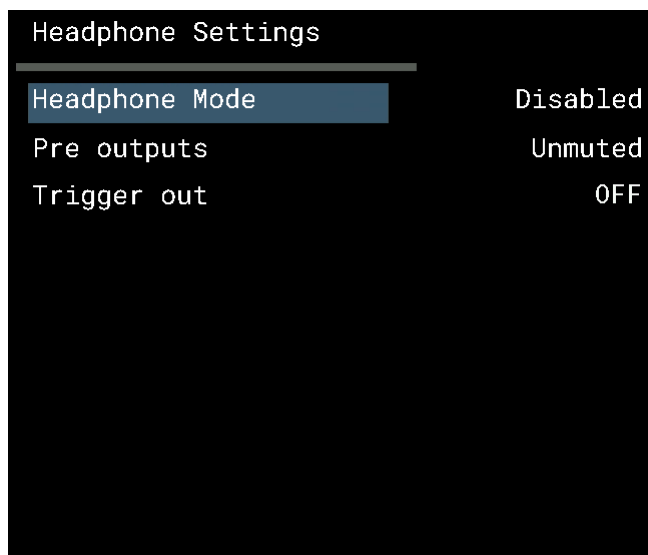



Headphone Mode is designed to allow you to connect a headphone amplifier to the SP25, for headphone listening. There are two options:

- You can connect the headphone amplifier to **LINE OUT**; this will make the volume independent of the SP25 volume, so you can control the headphones from the headphone amplifier. To select this mode set **Pre outputs** to **Muted**.
- Alternatively you can connect the headphone amplifier to **FRONT 1** or **FRONT 2**, which will allow you to control the headphone volume from the SP25. To select this mode set **Pre outputs** to **Unmuted**.

When Headphone Mode is enabled the **LINE OUT** and **FRONT 1** and **2** outputs are changed to full range, 2-channel configuration, and all the other **ANALOG OUT** outputs are muted.

You can toggle Headphone Mode on and off by pressing and holding  on the PRISMA remote (or C25 remote). When active, **HP** will be shown in front of the current volume setting in the front-panel and on-screen displays. When deactivated the volume will return to the **Default Volume** setting.

Headphone Mode: Choose **Enabled** to activate Headphone Mode or **Disabled** (default) to disable it.

Pre outputs: Allows you to specify whether the **FRONT 1 & 2** outputs will be **Muted** (default) or **Unmuted** while Headphone Mode is enabled.

Trigger out: Choose between **OFF** (default) to turn off the **TRIG OUT** signal while Headphone Mode is enabled, or **ON** to activate the **TRIG OUT** signal. Setting **Trigger out** to **OFF** allows you to turn off amplifiers controlled by the SP25 **TRIG OUT** signal when entering Headphone Mode for headphone listening.

Video Settings

The **Video Settings** menu allows you to configure the video outputs:

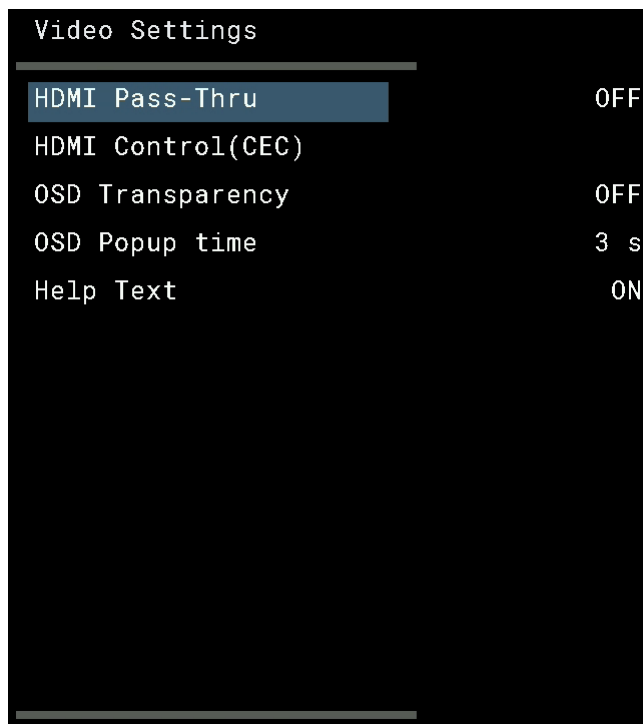

HDMI Pass-Thru

By default **HDMI Pass-Thru** is **OFF**, so HDMI OUT is off when the SP25 is in standby.

If you want the TV to be connected even when the SP25 is in standby, set **HDMI Pass-Thru** to either **HDMI MAIN** or **HDMI AUX** to connect HDMI IN 1 to HDMI AUX or MAIN output, while in standby.

Please note that HDMI pass-thru is only possible from HDMI IN 1 input.

HDMI Control (CEC)

Displays the **HDMI Control (CEC)** menu to allow you configure the HDMI control settings for this preset.

You can use CEC to automatically bring the TV connected to the SP25 out of standby when you select a video source on the SP25.

By default HDMI CEC is **OFF**. Setting it to **ON** allows you to set each of the subsequent options **Ignore Power On**, **Ignore Power Off**, and **Ignore Switch Source** to NO or YES to determine how the source behaves.

OSD Transparency

Choose **ON** (the default) or **OFF** to determine if the OSD has a transparent background.

OSD Popup Time

Can be set to **Always** to leave the OSD permanently on the display, a time between **1s** and **10 s** to hide the OSD after a delay, or **Never** to never show the OSD.

Help text

Choose **ON** (the default) or **OFF** to choose whether help text is shown below each menu.



SP25 Prisma User Guide

CONTENTS

Safety information

Welcome!

Getting started

Back panel connections

Using the PRISMA remote

Using the SP25

Source options

Configuring the SP25

Setting up sources

Speaker configurations

Setting up speakers

Dirac Live

Other settings

Technical specification

Additional information

SPEAKER CONFIGURATIONS

This section describes some typical speaker configurations that you can choose with the SP25. For details of setting up each configuration see the next chapter [Setting up speakers](#).

Note: In the following diagrams the connection to each stereo pair of loudspeakers is shown as a single line, for clarity. Follow the R and L labels on the back panel when connecting each loudspeaker in a pair.

2.0 Stereo system

Uses speakers for Front Left and Front Right:

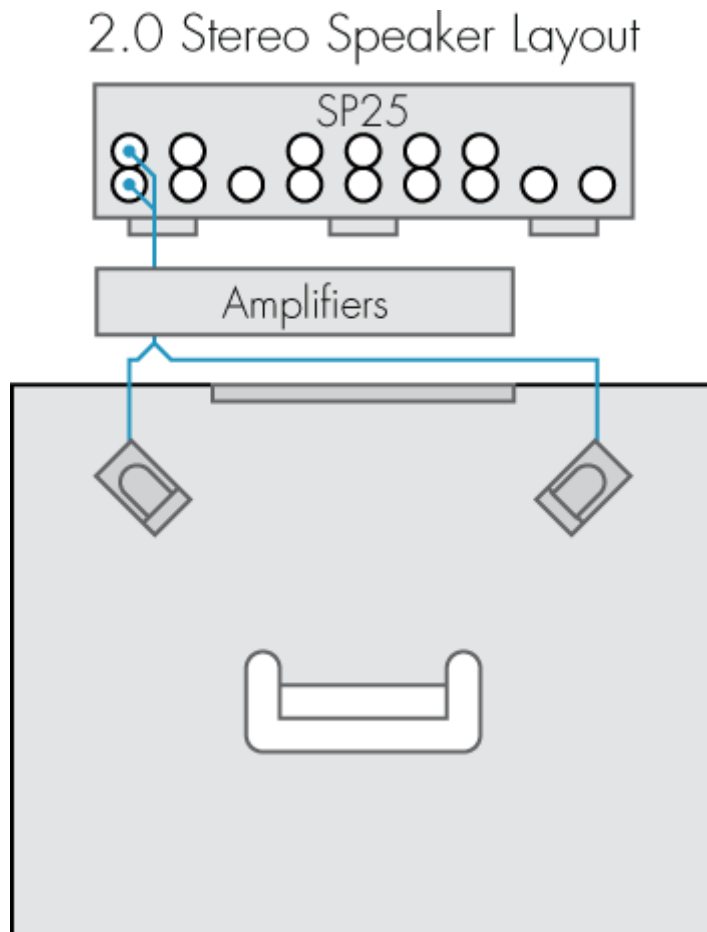

Set the options in the **Speaker Setup** menu as follows:

- Center – OFF
- Surround L&R – OFF
- Subwoofer – OFF
- Surr. Back – OFF
- Height Front L&R – OFF
- Height Back L&R – OFF

Then connect up the speakers as follows:

- Connect the FRONT 1 Left and FRONT 1 Right ANALOG OUT connections to amplifiers driving the Front Left and Right speakers.

2.0 Bi-Amp system

Allows you to bi-amp to Front Left and Front Right speakers with separate bass and treble units:

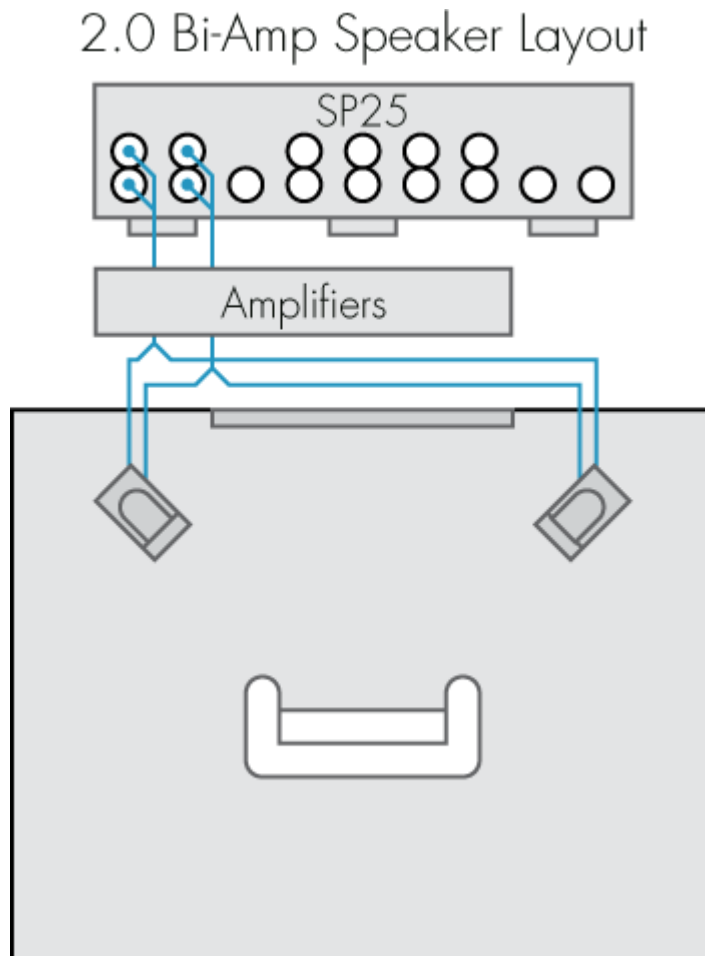

Set the options in the **Speaker Setup** menu as follows:

- Center – OFF
- Surround L&R – OFF
- Subwoofer – OFF
- Surr. Back – OFF
- Height Front L&R – OFF
- Height Back L&R – OFF

Then connect up the speakers as follows:

- Connect the FRONT 1 Left and FRONT 1 Right ANALOG OUT connections to amplifiers driving the bass units of the Front Left and Right speakers, and the FRONT 2 Left and FRONT 2 Right ANALOG OUT connections to amplifiers driving the treble units of the Front Left and Right speakers.

5.1 Dolby/DTS system

Uses speakers for Front Left, Front Right, and Centre, and Surround Left and Right:

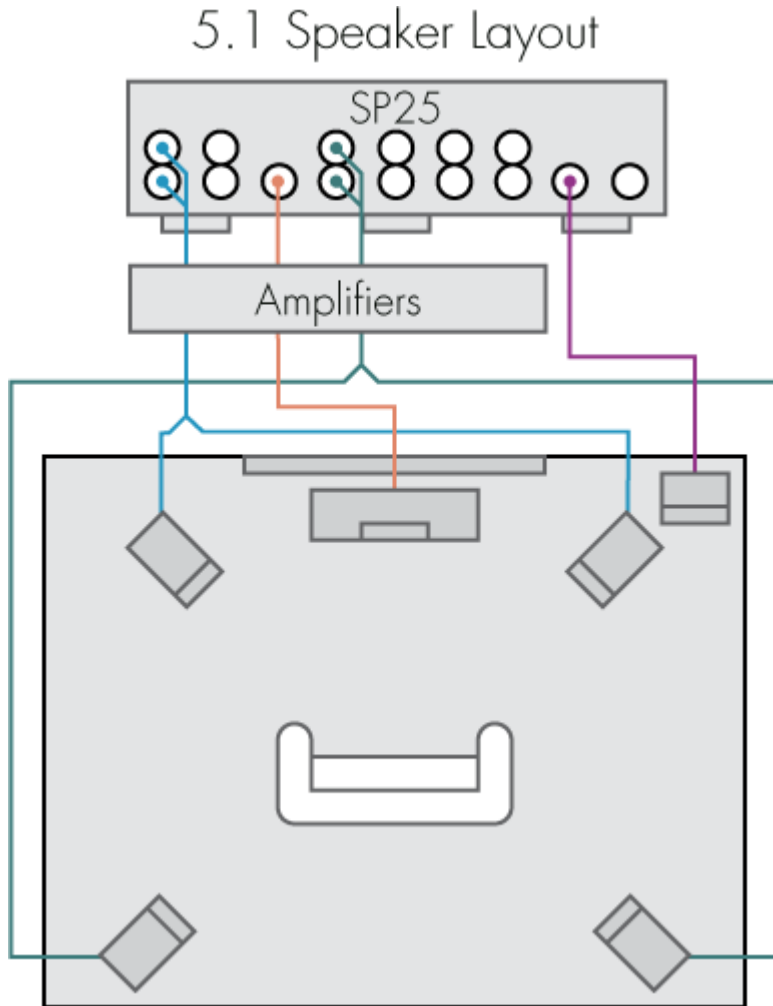

Set the options in the **Speaker Setup** menu as follows:

- Center – ON
- Surround L&R – ON
- Subwoofer – ON
- Surr. Back – OFF
- Height Front L&R – OFF
- Height Back L&R – OFF

Then connect up the speakers as follows:

- Connect the FRONT 1 Left and FRONT 1 Right ANALOG OUT connections to amplifiers driving the Front Left and Right speakers.
- Connect the SURR Left and Right ANALOG OUT connections to amplifiers driving the Surround Back speakers.
- **Full Range** is default setting, if crossover needs to be applied see [Setting up](#)

speakers: Crossover

5.1 Bi-Amp system

Bi-Amps to the Front Left and Right speakers, and provides Centre, and Surround Left and Right:

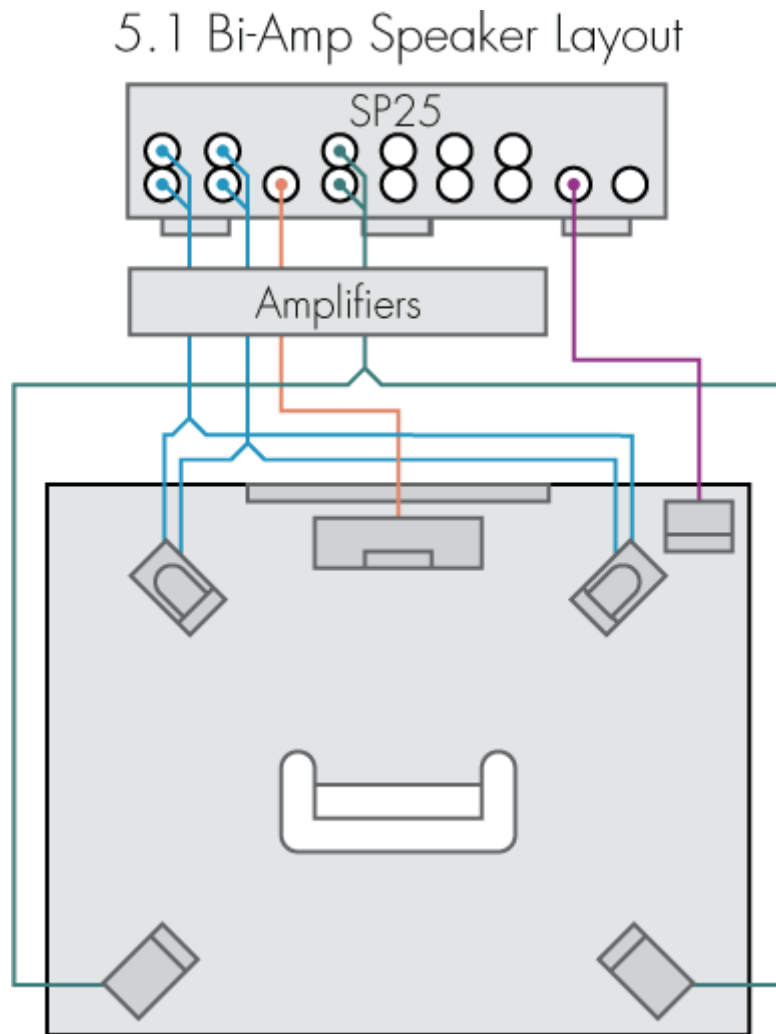

Set the options in the **Speaker Setup** menu as follows:

- Center – ON
- Surround L&R – ON
- Subwoofer – ON
- Surr. Back – OFF
- Height Front L&R – OFF
- Height Back L&R – OFF

Then connect up the speakers as follows:

- Connect the FRONT 1 Left and FRONT 1 Right ANALOG OUT connections to

amplifiers driving the bass units of the Front Left and Right speakers, and the FRONT 2 Left and FRONT 2 Right ANALOG OUT connections to amplifiers driving the treble units of the Front Left and Right speakers.

- Connect the SURR Left and Right ANALOG OUT connections to amplifiers driving the Surround Back speakers.
- **Full Range** is default setting, if crossover needs to be applied see [Setting up speakers: Crossover](#)

7.1 Dolby/DTS system

Uses speakers for Front Left and Right, Centre, Surround Left and Right, and Surround Back Left and Right:

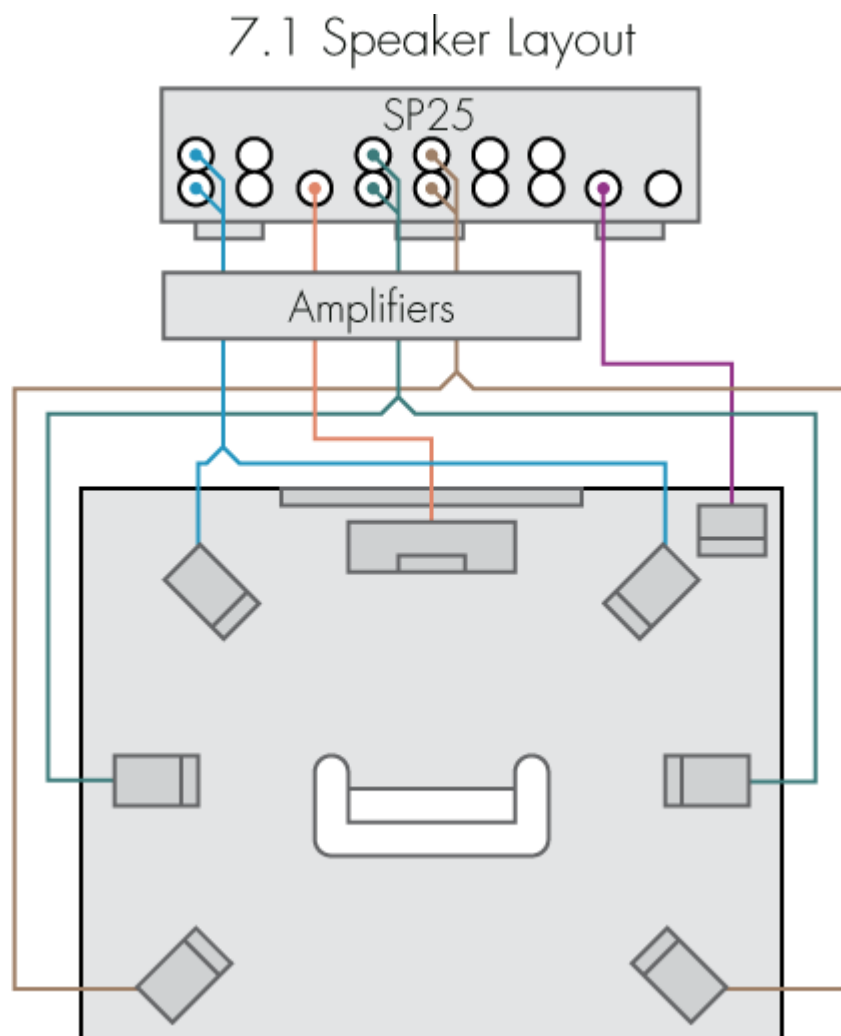

Set the options in the **Speaker Setup** menu as follows:

- Center – ON
- Surround L&R – ON
- Subwoofer – ON

- Surr. Back – ON
- Height Front L&R – OFF
- Height Back L&R – OFF

Then connect up the speakers as follows:

- Connect the FRONT 1 Left and FRONT 1 Right ANALOG OUT connections to amplifiers driving the Front Left and Right speakers.
- Connect the CENTER ANALOG OUT connection to an amplifier driving the Center speaker.
- Connect the SURR Left and Right ANALOG OUT connections to amplifiers driving the Surround Side speakers.
- Connect the SURR BACK Left and Right ANALOG OUT connections to amplifiers driving the Surround Back speakers.
- **Full Range** is default setting, if crossover needs to be applied see [Setting up speakers: Crossover](#)

7.1 Bi-Amp system

Bi-Amps to the Front Left and Right speakers, and provides Centre, Surround Left and Right, and Surround Back Left and Right:

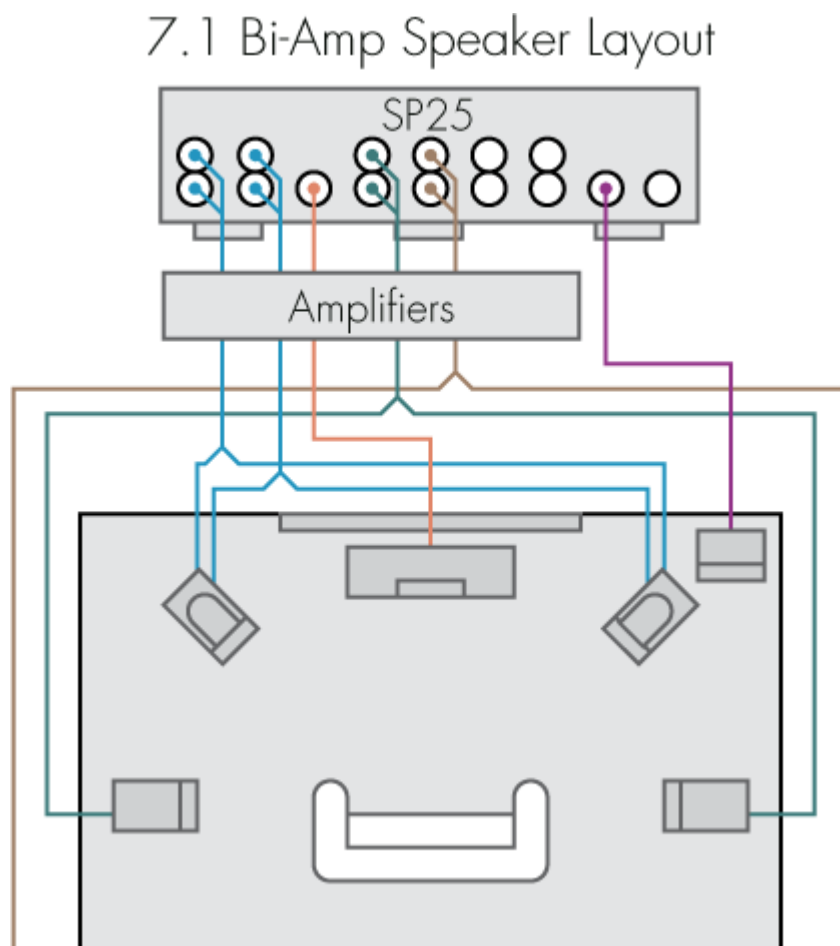



Set the options in the **Speaker Setup** menu as follows:

- Center – ON
- Surround L&R – ON
- Subwoofer – ON
- Surr. Back – ON
- Height Front L&R – OFF
- Height Back L&R – OFF

Then connect up the speakers as follows:

- Connect the FRONT 1 Left and FRONT 1 Right ANALOG OUT connections to amplifiers driving the bass units of the Front Left and Right speakers, and the FRONT 2 Left and FRONT 2 Right ANALOG OUT connections to amplifiers driving the treble units of the Front Left and Right speakers.
- Connect the CENTER ANALOG OUT connection to an amplifier driving the Center speaker.
- Connect the SURR Left and Right ANALOG OUT connections to amplifiers driving the Surround Side speakers.
- Connect the SURR BACK Left and Right ANALOG OUT connections to amplifiers driving the Surround Back speakers.
- Set the crossover frequency for the Front Left, Front Right, Height Left, and Height Right speakers to **Full Range**, to use the crossovers in the speakers; see [Setting up speakers: Crossover](#).
- **Full Range** is default setting, if crossover needs to be applied see [Setting up speakers: Crossover](#)

5.1.2 Dolby Atmos/DTS:X system

Uses speakers for Front Left and Right, Centre, Surround Left and Right, and Height Left and Right:

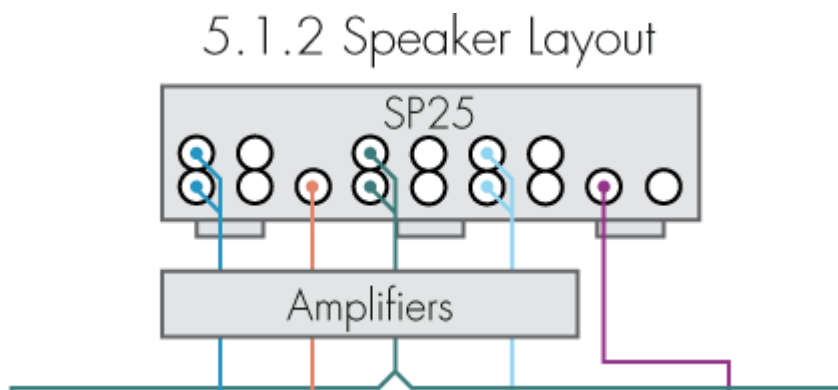

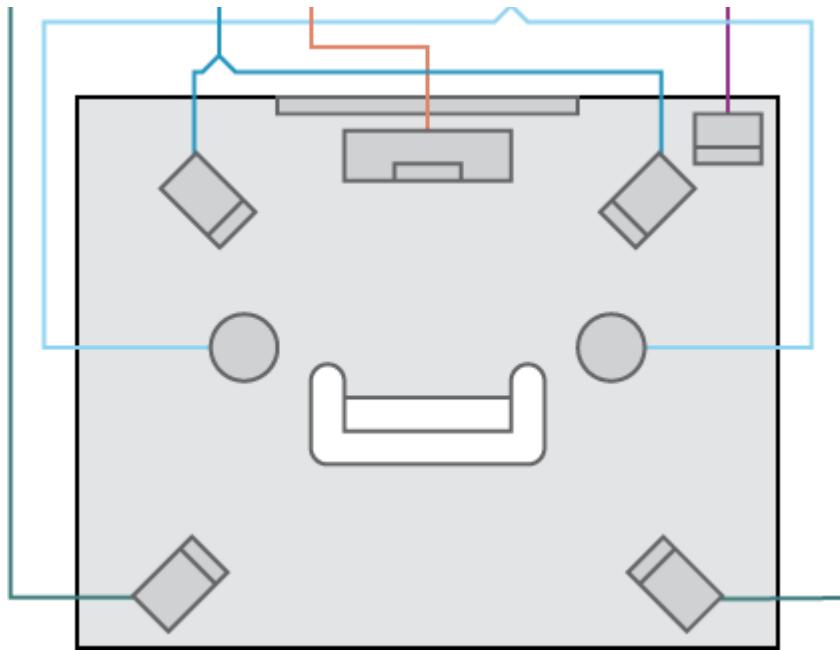

Set the options in the **Speaker Setup** menu as follows:

- Center – ON
- Surround L&R – ON
- Subwoofer – ON
- Surr. Back – OFF
- Height Front L&R – ON
- Height Back L&R – OFF

Then connect up the speakers as follows:

- Connect the FRONT 1 Left and FRONT 1 Right ANALOG OUT connections to amplifiers driving the Front Left and Right speakers.
- Connect the CENTER ANALOG OUT connection to an amplifier driving the Center speaker.
- Connect the SURR Left and Right ANALOG OUT connections to amplifiers driving the Surround Back speakers.
- Connect the HEIGHT FRONT Left and Right ANALOG OUT connections to amplifiers driving the TOP MIDDLE speakers.
- **Full Range** is default setting, if crossover needs to be applied see [Setting up speakers: Crossover](#)

7.1.2 Atmos/DTS:X system

Uses nine speakers for Front Left and Right, Centre, Surround Left and Right, Surround Back Left and Right, and Height Left and Right:

7.1.2 Speaker layout

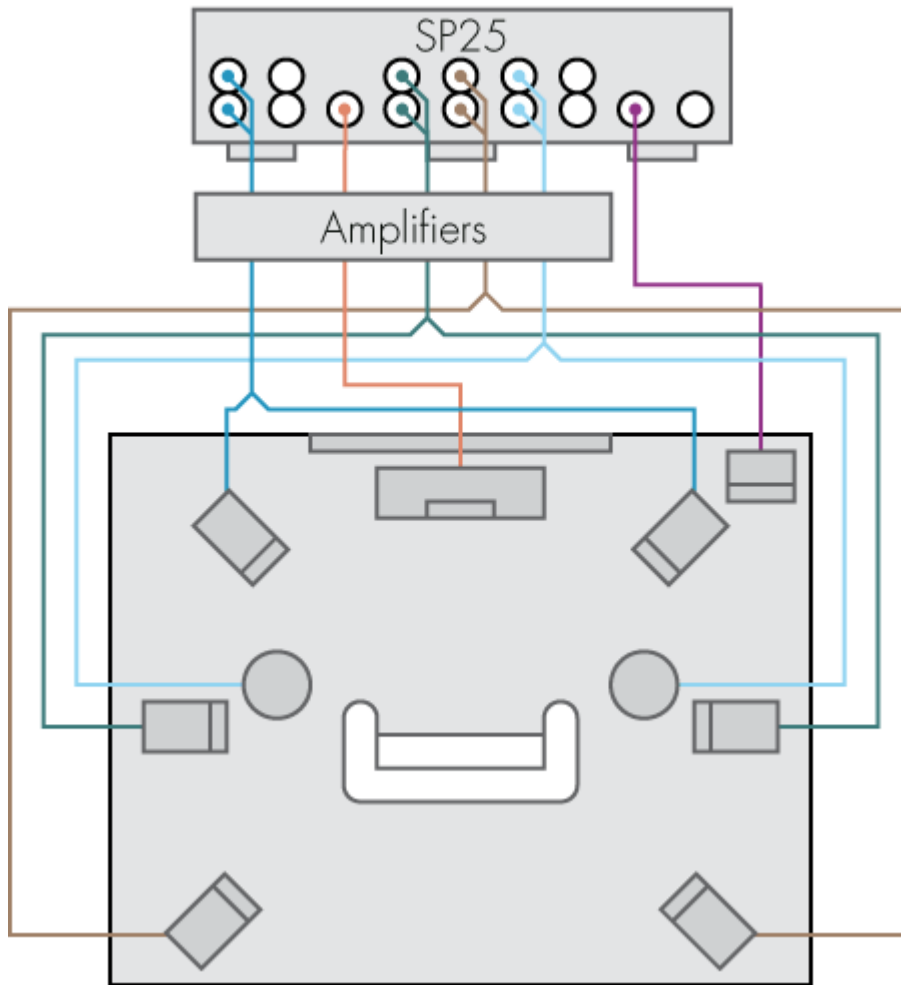

Set the options in the **Speaker Setup** menu as follows (these are the default settings):

- Center – ON
- Surround L&R – ON
- Subwoofer – ON
- Surr. Back – ON
- Height Front L&R – ON
- Height Back L&R – OFF

Then connect up the speakers as follows:

- Connect the FRONT 1 Left and FRONT 1 Right ANALOG OUT connections to amplifiers driving the Front Left and Right speakers.
- Connect the CENTER ANALOG OUT connection to an amplifier driving the Center speaker.
- Connect the SURR Left and Right ANALOG OUT connections to amplifiers driving the Surround Side speakers.
- Connect the SURR BACK Left and Right ANALOG OUT connections to amplifiers driving the Surround Back speakers.

- Connect the HEIGHT FRONT Left and Right ANALOG OUT connections to amplifiers driving the TOP MIDDLE speakers.
- **Full Range** is default setting, if crossover needs to be applied see [Setting up speakers: Crossover](#)

5.1.4 Atmos/DTS:X system

Uses nine speakers for Front Left and Right, Centre, Surround Left and Right, and Height Front Left and Right, and the Height Back Left and Right:

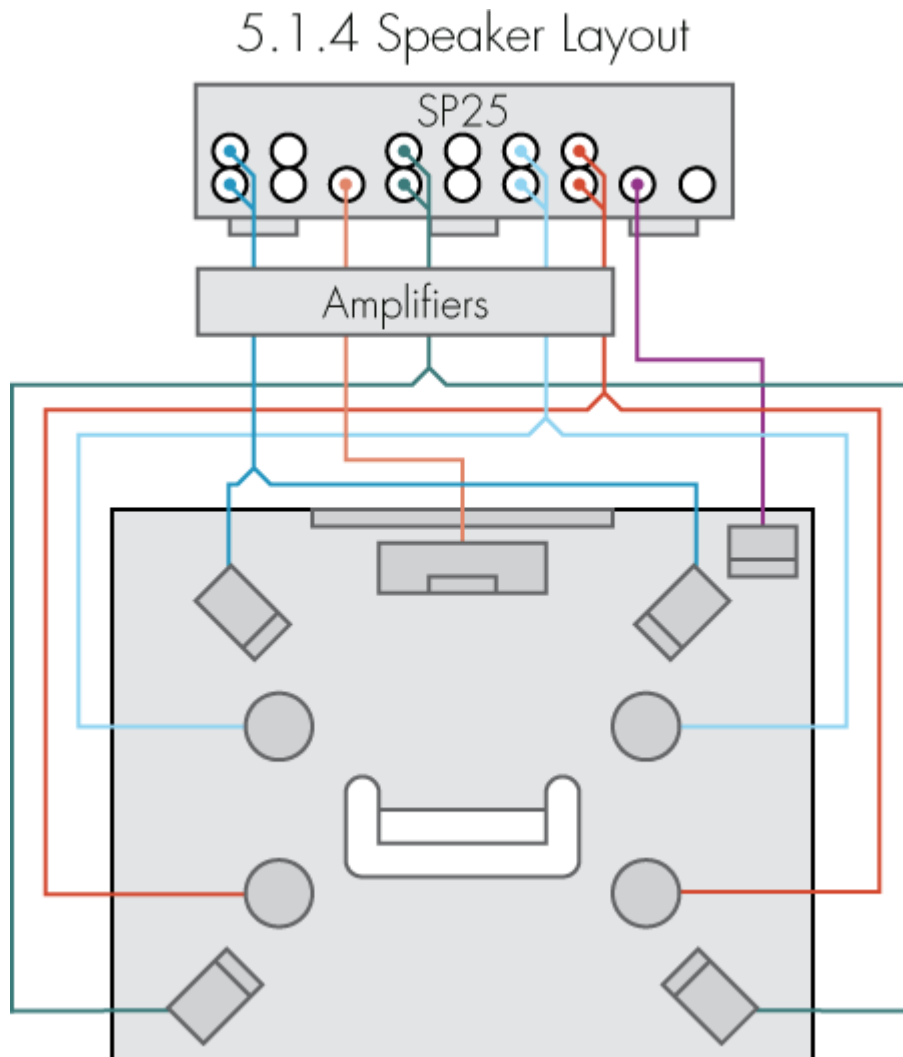

Set the options in the **Speaker Setup** menu as follows:

- Center – ON
- Surround L&R – ON
- Subwoofer – ON
- Surr. Back – OFF
- Height Front L&R – ON
- Height Back L&R – ON

Then connect up the speakers as follows:

- Connect the FRONT 1 Left and FRONT 1 Right ANALOG OUT connections to amplifiers driving the Front Left and Right speakers.
- Connect the CENTER ANALOG OUT connection to an amplifier driving the Center speaker.
- Connect the SURR Left and Right ANALOG OUT connections to amplifiers driving the Surround speakers.
- Connect the HEIGHT FRONT Left and Right ANALOG OUT connections to amplifiers driving the Height Front speakers.
- Connect the HEIGHT BACK Left and Right ANALOG OUT connections to amplifiers driving the Height Back speakers.
- **Full Range** is default setting, if crossover needs to be applied see [Setting up speakers: Crossover](#)

7.1.4 Atmos system

Uses 11 speakers for Front Left and Right, Centre, Surround Left and Right, Surround Back Left and Right, and Height Front Left and Right, and Height Rear Left and Right.

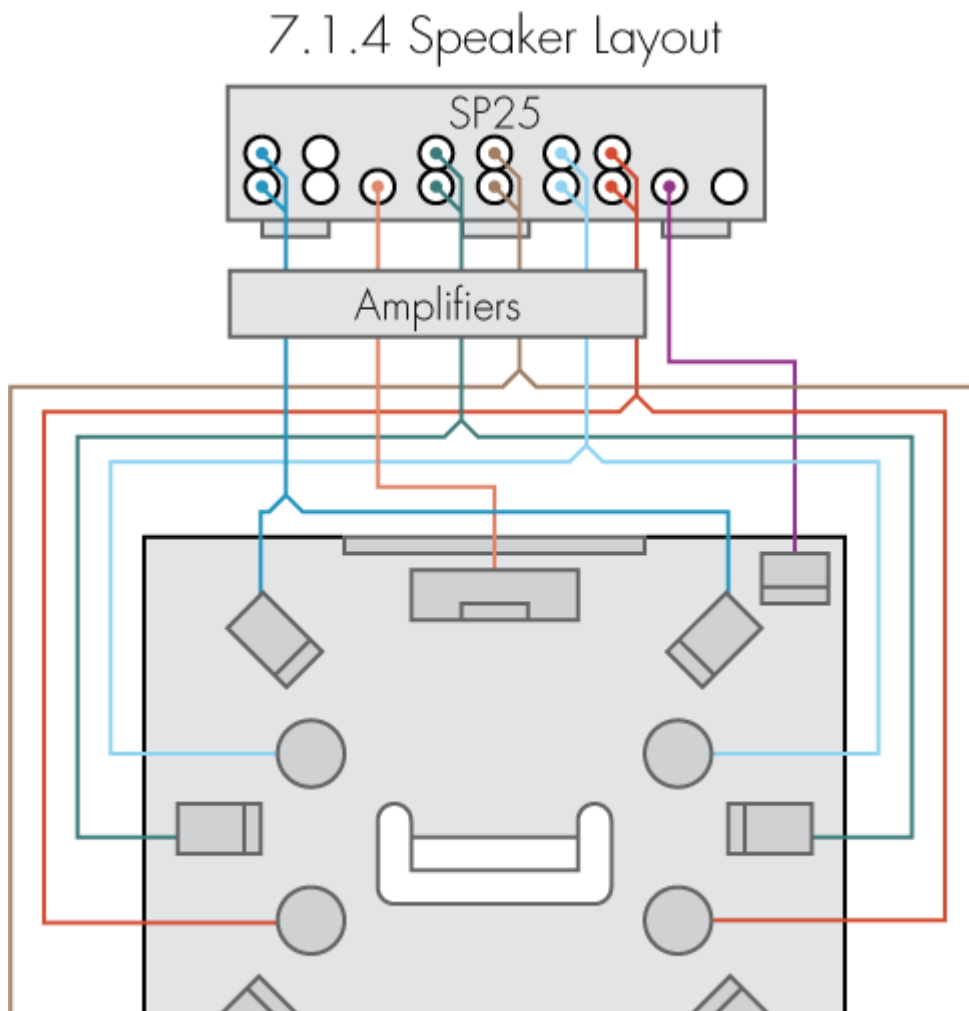



Set the options in the **Speaker Setup** menu as follows:

- Center – ON
- Surround L&R – ON
- Subwoofer – ON
- Surr. Back – ON
- Height Front L&R – ON
- Height Back L&R – ON

Then connect up the speakers as follows:

- Connect the FRONT 1 Left and FRONT 1 Right ANALOG OUT connections to amplifiers driving the Front Left and Right speakers.
- Connect the CENTER ANALOG OUT connection to an amplifier driving the Center speaker.
- Connect the SURR Left and Right ANALOG OUT connections to amplifiers driving the Surround Side speakers.
- Connect the SURR BACK Left and Right ANALOG OUT connections to amplifiers driving the Surround Back speakers.
- Connect the HEIGHT FRONT Left and Right ANALOG OUT connections to amplifiers driving the Height Front speakers.
- Connect the HEIGHT BACK Left and Right ANALOG OUT connections to amplifiers driving the Height Back speakers.
- **Full Range** is default setting, if crossover needs to be applied see [Setting up speakers: Crossover](#)



SP25 Prisma User Guide

CONTENTS

Safety information

Welcome!

Getting started

Back panel connections

Using the PRISMA remote

Using the SP25

Source options

Configuring the SP25

Setting up sources

Speaker configurations

Setting up speakers

Dirac Live

Other settings

Technical specification

Additional information

SETTING UP SPEAKERS

After connecting up your loudspeakers, to get the correct balance of sound from your surround system you need to configure the settings in the four submenus on the **Speaker Settings** menu.

Speaker Settings

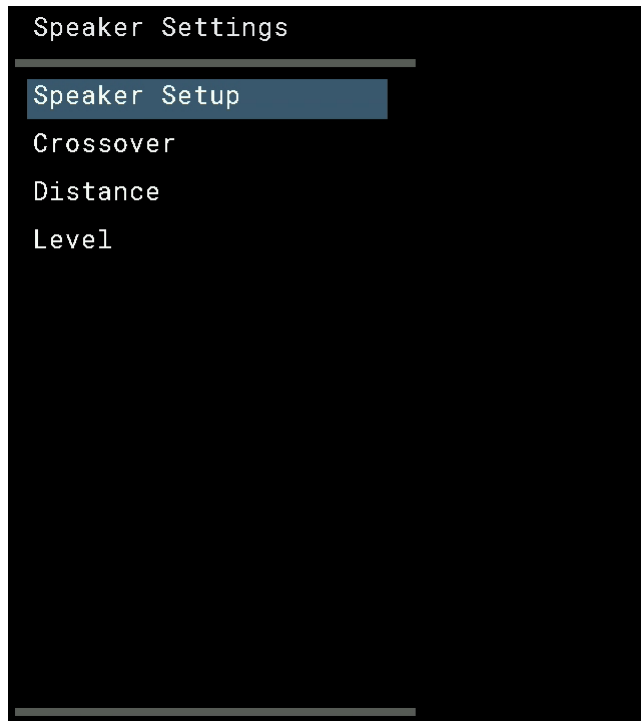

The procedure for setting up the surround system is as follows:

Speaker Setup

Specifies which speakers you have in your surround system.

Crossover

Allows you to specify the crossover characteristics to be applied to each speaker.

Distance

Allows you to set the **Distance** to the main listening position for each speaker.

Level

Allows you to adjust speaker **Level** so each speaker is equally loud at main listening position.

Presets

The speaker presets make it easy to save your settings as a single, named configuration. You can define up to five presets, initially called **Preset 1** to **Preset 5**, but you can give them names using the **Alias** option. You can access the speaker presets from each of the **Speaker Setup**, **Crossover**, **Distance**, and **Level** menus.

You only need to define one preset, but having more than one allows you to experiment with different configurations of your surround system. For example, you could have one preset optimised for solitary listening, and another which is ideal for watching movies with a crowd of friends.

Speaker Setup

The **Speaker Setup** menu allows you to define speaker presets, which configure the assignment of loudspeakers to the surround system.

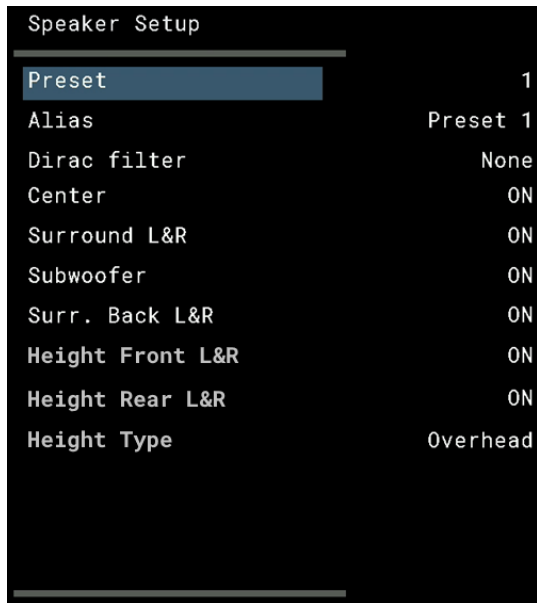

Preset

Lets you select which loudspeaker preset you are configuring. To specify the preset:

- Press **SELECT** on the PRISMA remote.
- Press ◀ or ▶ on the PRISMA remote to step to the preset you want to edit.
- Press **SELECT** to select it.

Alias

Allows you to give the loudspeaker preset a memorable name. See [Configuring the SP25: Editing an alias](#) for details of entering an alias.

Dirac filter

Choose **None** (the default) if you are not using Dirac, or **Slot 1** to **Slot 4** to specify which Dirac configuration you want to use.

Center

Choose **ON** (the default) if you have a loudspeaker connected to the Centre output, or **OFF** if there is no Centre loudspeaker.

Surround L&R

Choose **ON** (the default) if you have loudspeakers connected to the Surround Left and Right outputs, or **OFF** if there are no Surround Left and Right loudspeakers in the system.

Subwoofer

Choose **ON** (the default) if you have a subwoofer connected to the **SUB 1** analogue output, or **OFF** if there is no subwoofer in the system.

Surr. Back L&R

Choose **ON** (the default) if you have loudspeakers connected to the Surround Back Left and Right outputs, or **OFF** if there are no Surround Back Left and Right loudspeakers in the system.

Height Front L&R

Choose **ON** (the default) if you have loudspeakers connected to the Height Front Left and Right outputs, or **OFF** if there are no Height Front Left and Right loudspeakers in the system.

Height Rear L&R

Choose **ON** (the default) if you have loudspeakers connected to the Height Front Left and Right outputs, or **OFF** if there are no Height Front Left and Right loudspeakers in the system

Height Type

Choose **Overhead** (the default) if the height speakers are ceiling mounted, pointing down into the room, or **Upward Firing** if they are pointing at the ceiling.

When the **Height Type** is set to **Upward Firing** the SP25 Height outputs are set as Dolby Atmos enabled speakers. When the Height Type is set to **Overhead** the SP25 Height outputs are set as normal speakers.

Crossover

Allows you to specify the crossover characteristics.



Dirac filter	None
Front L&R	Full Range
Center	Full Range
Surround L&R	Full Range
Surr. Back L&R	Full Range
Height Front L&R	Full Range
Height Rear L&R	Full Range
LFE	200 Hz

Preset

Lets you select which crossover preset you are configuring. To specify the preset:

- Press **SELECT** on the PRISMA remote.
- Press ◀ or ▶ on the PRISMA remote to step to the preset you want to edit.
- Press **SELECT** to select it.

Alias

Allows you to give the speaker preset a memorable name. See [Configuring the SP25: Editing an alias](#) for details of entering an alias.

Dirac filter

Choose **None** (the default) if you are not using Dirac, or **Slot 1** to **Slot 4** to specify which Dirac configuration you want to use.

Front L&R, Center, Surround L&R, Surround Back L&R, Height L&R, Height Real L&R, Subwoofer

These menus allow you to specify the crossover frequency for each speaker or pair of speakers.

You can choose **Full Range** (the default), or a crossover frequency from **40 Hz** to **200 Hz** in steps of 10 Hz.

You can hold down ▲ or ▼ on the PRISMA remote to change the setting rapidly, and you will hear the effect in the current source you are listening to upon pressing select.

If you don't have a subwoofer in your system, at least one pair of loudspeakers will be set to **Full Range** to handle the bass in the surround system.

If no speakers are defined as **Full Range**, the subwoofer receives the LFE signal (when

available), plus the bass from each channel.

If one or more speakers are defined as **Full Range**, the subwoofer receives the LFE signal (when available). You can also choose to send the subwoofer(s) a copy of the bass from the **Full Range** speakers by setting **Double Bass** to **ON**; see [Setting up sources: Audio settings](#).

Distance

Allows you to specify the distance of each loudspeaker from the listening position.

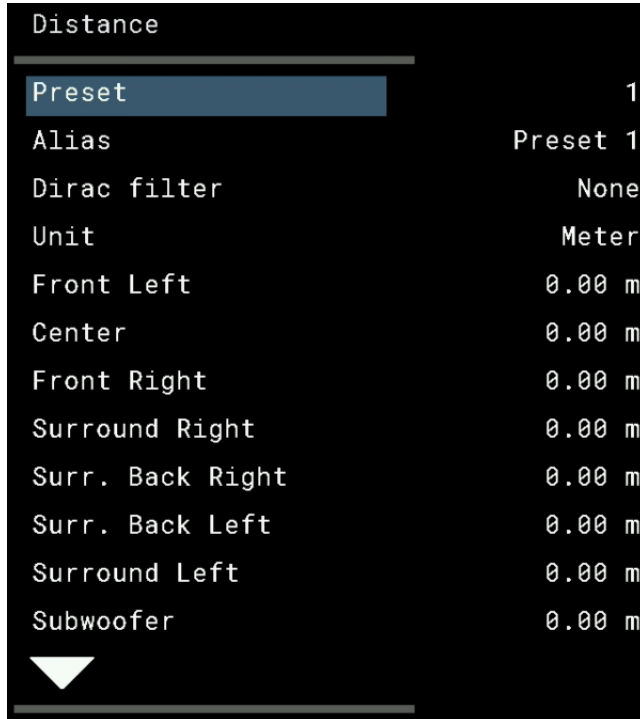

Distance	
Preset	1
Alias	Preset 1
Dirac filter	None
Unit	Meter
Front Left	0.00 m
Center	0.00 m
Front Right	0.00 m
Surround Right	0.00 m
Surr. Back Right	0.00 m
Surr. Back Left	0.00 m
Surround Left	0.00 m
Subwoofer	0.00 m

Preset

Lets you select which distance preset you are configuring. To specify the preset:

- Press **SELECT** on the PRISMA remote.
- Press ◀ or ▶ on the PRISMA remote to step to the preset you want to edit.
- Press **SELECT** to select it.

Alias

Allows you to give the speaker preset a memorable name. See [Configuring the SP25: Editing an alias](#) for details of entering an alias.

Dirac filter

Choose **None** (the default) if you are not using Dirac, or **Slot 1** to **Slot 4** to specify which Dirac configuration you want to use. If you have a Dirac filter active the values will be

grayed out as Dirac by default does distance setup upon calibration.

Unit

Choose **Meter** (the default) to measure distances in meters or **Feet** to measure distances in feet.

Front Left, Center, Front Right, Surround Right, Surr. Back Right, Surr. Back Left, Surround Left, Subwoofer, Height Right, Height Left, Height Rear Right, Height Rear Left

These menus allow you to specify the distance of each speaker from the listening position.

The speakers go in order clockwise around the layout, starting from Front Left. In this menu you can specify the left and right speakers in each pair individually, because they may not be exactly the same distance from the listening position.

The range of options is as follows:

Unit	Range
Meter	0.00 m to 12.00 m in steps of 0.10 m
Feet	0.00 ft to 39.36 ft in steps of about 0.32 ft

You can hold down ▲ or ▼ on the PRISMA remote to change the setting rapidly, and you will hear the effect in the current source you are listening to upon pressing select.

Level

Allows you to adjust the relative level of each loudspeaker.

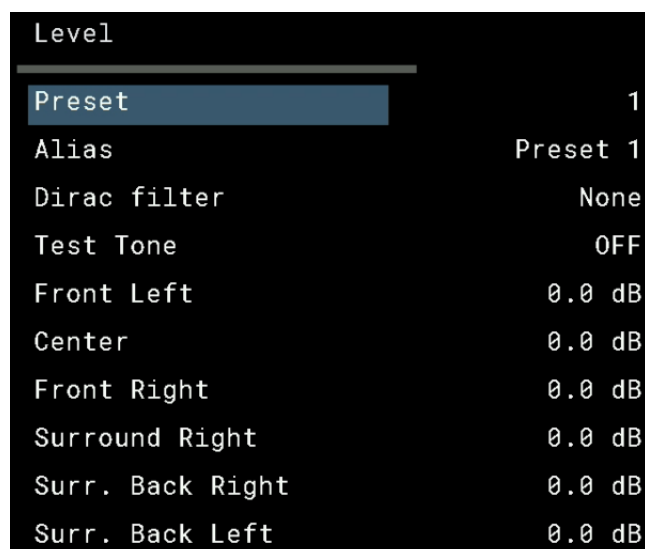

A screenshot of a menu titled "Level" with a dark background and white text. The menu items and their values are as follows:

Level	
Preset	1
Alias	Preset 1
Dirac filter	None
Test Tone	OFF
Front Left	0.0 dB
Center	0.0 dB
Front Right	0.0 dB
Surround Right	0.0 dB
Surr. Back Right	0.0 dB
Surr. Back Left	0.0 dB

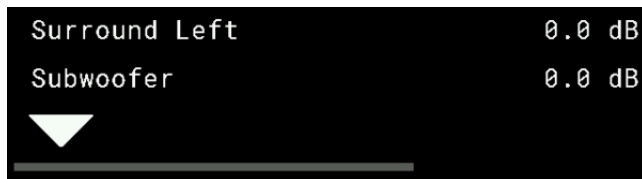

Preset

Lets you select which level preset you are configuring. To specify the preset:

- Press **SELECT** on the PRISMA remote.
- Press ◀ or ▶ on the PRISMA remote to step to the preset you want to edit.
- Press **SELECT** to select it.

Alias

Allows you to give the speaker preset a memorable name. See [Configuring the SP25: Editing an alias](#) for details of entering an alias.

Dirac filter

Choose **None** (the default) if you are not using Dirac, or **Slot 1** to **Slot 4** to specify which Dirac configuration you want to use. If you have a Dirac filter active the values will be grayed out as Dirac by default does level setup upon calibration.

Test Tone

Plays a test tone instead of the current source.

Front Left, Center, Front Right, Surround Right, Surr. Back Right, Surr. Back Left, Surround Left, Subwoofer, Height Right, Height Left, Height Rear Right, Height Rear Left

These menus allow you to adjust the level of each loudspeaker, from -12.0 dB (quieter), to 0.0 dB (the default), to +12.0 dB (louder).

The speakers go in order clockwise around the layout, starting from Front Left. In this menu you can specify the left and right speakers in each pair individually, because they may not sound equally loud at the listening position.

You can hold down ▲ or ▼ on the PRISMA remote to change the setting rapidly, and you will hear the effect in the current source you are listening to, or the test tone if you have chosen that upon pressing select.



SP25 Prisma User Guide

CONTENTS

Safety information

Welcome!

Getting started

Back panel connections

Using the PRISMA remote

Using the SP25

Source options

Configuring the SP25

Setting up sources

Speaker configurations

Setting up speakers

Dirac Live

Other settings

Technical specification

Additional information

DIRAC LIVE

The interaction between your Primare system and the physical layout of your room has a huge impact on sound quality. With Dirac Live® Room Correction you can apply state-of-the-art, patented algorithms to analyse and digitally reduce room impact and enhance

speaker performance through your Primare system. Dirac Live delivers a larger sweet spot, accurate staging, clarity, voice intelligibility, and a deeper, tighter bass not otherwise possible.

Key Benefits

With Dirac Live Room Correction you will experience three key benefits:

1. Improved localisation of sound events, so called staging.
2. Better clarity and intelligibility in music and speech.
3. A deeper and tighter bass free of resonances throughout the entire listening area.

Note: A Limited Bandwidth Dirac Live subscription tier is included with the SP25. Alternatively, you can order the Full Bandwidth Dirac Live subscription directly from Dirac on their [website](#).

For more information see <https://primare.net/dirac/>

Dirac Live Quick Start Guide

1. [Download Dirac Live](#).
2. Create a [Dirac account](#).
3. If needed, [buy a license](#) for your device and follow activation instructions.
4. Log in to Dirac Live on your device.
5. [Calibrate](#) and enjoy!

Note: An Ethernet connection must be used for Dirac Live updating and calibration. Once the settings have been determined and filters loaded into the SP25 Prisma an Ethernet connection is not necessary although we, as does Dirac, recommend using that connection if possible.



SP25 Prisma User Guide

CONTENTS

Safety information

Welcome!

Getting started

Back panel connections

Using the PRISMA remote

Using the SP25

Source options

Configuring the SP25

Setting up sources

Speaker configurations

Setting up speakers

Dirac Live

Other settings

Technical specification

Additional information

OTHER SETTINGS

General Settings

The **General Settings** menu allows you to configure the general operation of the SP25:

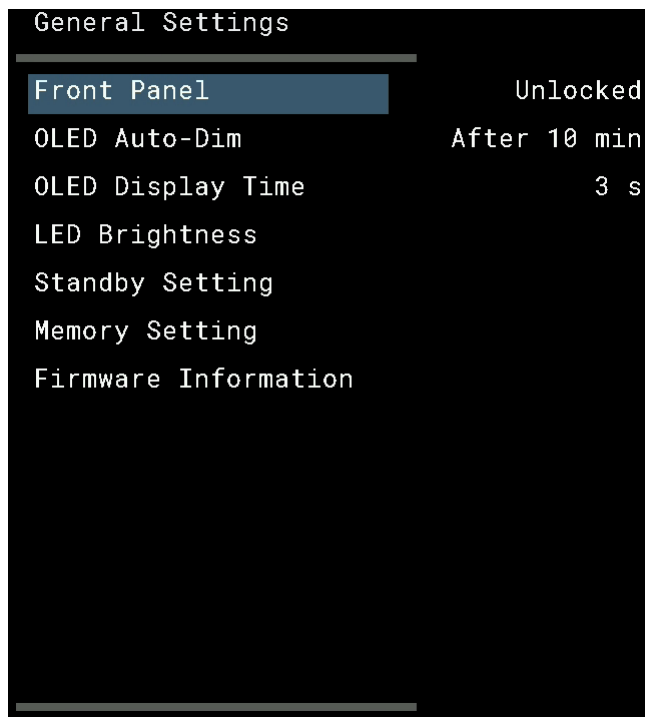

Front Panel

Choose **Locked** to lock the front panel controls, or **Unlocked** (default) to use them.

To unlock the front panel controls use the remote control to select this menu, or remove power from the SP25 for a few seconds.

OLED Auto-Dim

Allows you to choose the delay for dimming the front-panel display after no user interaction, between: **Never**, **After 10 min**, **After 5 min**, or **After 1 min**.

OLED Display Time

Specifies how long the OLED display shows the information before dimming, between: **Never**, or **1 s** to **10 s**.

LED Brightness

Allows you to specify the brightness of the LEDs illuminating the buttons on the front panel. Displays the **LED BRIGHTNESS** menu to allow you to set the display brightness to between 1 and 5 for each display dimming level:

DIM HIGH (default 3), **DIM MID** (default 2), **DIM LOW** (default 1), or **DIM OFF** (default 1).

Standby Setting

Provides two menus: **Standby Mode** and **Auto-Standby**.

Standby Mode can be set to **ECO** to reduce the standby consumption to less than 0.5W, but only allows the SP25 to wake from the analogue and digital inputs, or **Normal** which also allows the SP25 to wake from streaming and the PC/MAC input.

The SP25 is classified as a HiNA (high-network availability) product. If no audio stream signal is detected for 20 minutes the unit will automatically go into network standby mode, in which the power consumption of the device is <6W. The unit will exit from network standby mode when audio streaming is detected.

Auto-Standby automatically switches the SP25 to standby if there is no user interaction or audio from the current source for a specified delay: **Never, 60 Minutes, 40 Minutes, or 20 Minutes**.

Note: The **Auto-Standby** function will be disabled if the network has not been set up.

Memory Setting

Displays the **Memory Setting** menu:

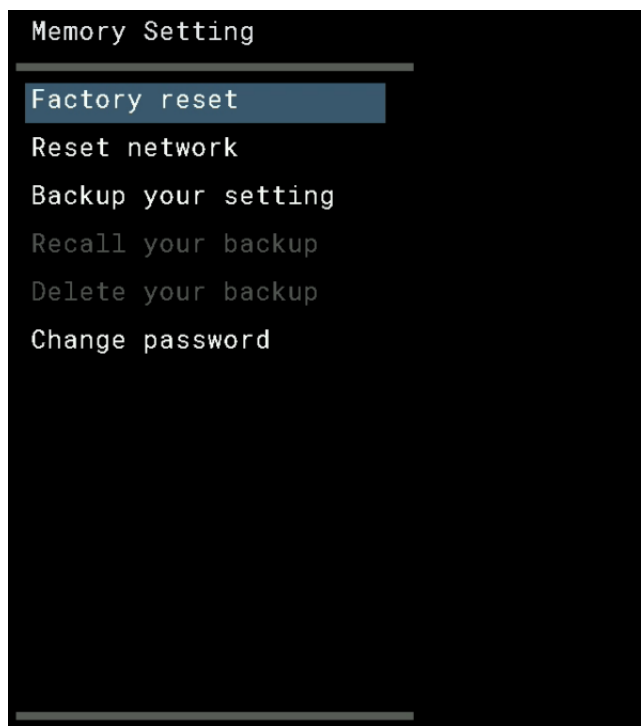

Factory reset resets the SP25 to default factory settings. Note that you will lose any configurations you have made. You are prompted to confirm. Select **YES** to proceed or **NO** to cancel.

Reset network resets the network configuration.

Backup your setting allows you to make a backup of your configuration. You can then

recall settings from a backup with **Recall your backup**, or delete the backup with **Delete your backup**.

Change password allows you to change the password.

Firmware Information

Displays the versions of firmware installed:

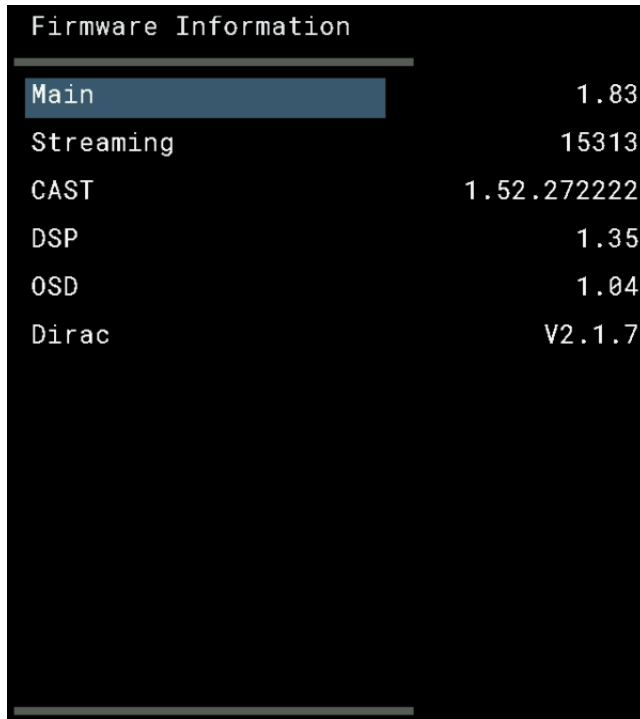
A screenshot of a terminal window showing the 'Firmware Information' menu. The menu is displayed on a black background with white text. The title 'Firmware Information' is at the top, followed by a horizontal separator line. Below the line, there are six entries, each with a blue highlight bar to its left. The entries are: 'Main' with version '1.83', 'Streaming' with version '15313', 'CAST' with version '1.52.272222', 'DSP' with version '1.35', 'OSD' with version '1.04', and 'Dirac' with version 'V2.1.7'.

Firmware Information	
Main	1.83
Streaming	15313
CAST	1.52.272222
DSP	1.35
OSD	1.04
Dirac	V2.1.7

Streaming Settings

Allows you to configure the SP25 streaming:

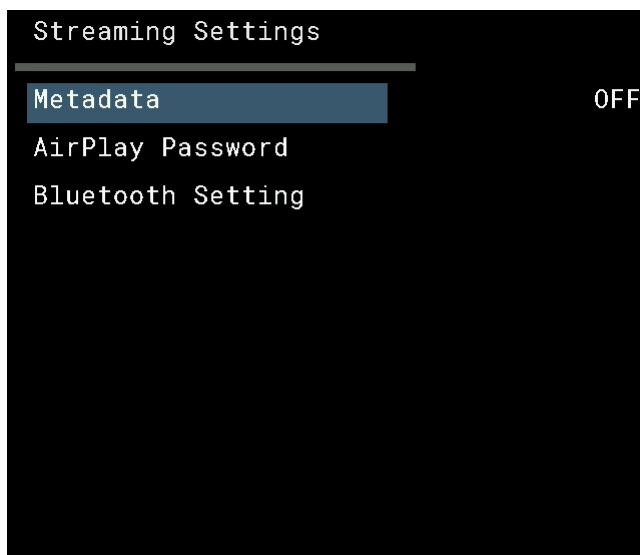
A screenshot of a terminal window showing the 'Streaming Settings' menu. The menu is displayed on a black background with white text. The title 'Streaming Settings' is at the top, followed by a horizontal separator line. Below the line, there are three entries, each with a blue highlight bar to its left. The entries are: 'Metadata' with the value 'OFF', 'AirPlay Password', and 'Bluetooth Setting'.

Streaming Settings	
Metadata	OFF
AirPlay Password	
Bluetooth Setting	



Metadata

Allows you to choose **OFF** (default) or **ON** to specify whether metadata, such as the artist name and song title, should be displayed.

AirPlay Password

Allows you to set an optional password for connection by AirPlay. Leave empty for no password.

Bluetooth Setting

Displays the **Bluetooth Setting** menu.

Visible can be set to **ON** to make the SP25 visible to other Bluetooth devices, or **OFF** (default) to hide the SP25 not visible.

Note: Visible allows any Bluetooth-enabled device within range to discover and pair with your SP25.

Auto-Connect can be set to **ON** to automatically reconnect to a paired mobile Bluetooth device when the Bluetooth input on the SP25 is selected, or **OFF** (default) to disable automatic connection.

Network Settings

Allows you to configure the network connection:

Network Settings	
Network status	WiFi
Network Name	No Connected
IP address	0.0.0.0
Net MAC	CC9093103A14
BT MAC	CC9093103A15
Dirac IP	255.255.255.255



Network Status

Shows **WiFi** or **Cable** to specify how the SP25 is connected to the network.

Network Name

Shows **Not Connected**, **Connected by Cable**, or the name of the WiFi network.

IP address

Shows the current IP address.

Net MAC

Shows the network MAC address.

BT MAC

Shows the current Bluetooth MAC address.

Dirac IP

Shows the IP address used to connect to Dirac.



SP25 Prisma User Guide

CONTENTS

Safety information

Welcome!

Getting started

Back panel connections

Using the PRISMA remote

Using the SP25

Source options

Configuring the SP25

Setting up sources

Speaker configurations

Setting up speakers

Dirac Live

Other settings

Technical specification

Additional information

TECHNICAL SPECIFICATION

Analogue outputs

15 channels

Front 1 (left and right)
Front 2 (left and right)
Center
Surround (left and right)
Surr back (left and right)
Height front (left and right)
Height back (left and right)
Sub (two outputs)

Line out (left and right)

Gain

16.5dB

Maximum output level

4V

Output impedance

100Ω

Performance

Frequency response

20Hz – 22kHz +0.2/-0.5dB (no EQ)

THD+N 20Hz-20kHz, 8Ω

< 0.08% @ rated output power

< 0.02% @ 10W

Signal to noise ratio

> 100dB (8Ω; A weighted at rated power)

Analog inputs

5 x RCA (left and right) with 7.1 input option

Input Impedance

15kΩ

Input sensitivity

90W 8Ω = 185mV

Audio processing

Decoding formats

Dolby Atmos

Dolby Digital

Dolby TrueHD

Dolby Plus

Dolby Surround

DTS X

DTS

DTS ES

DTS Neo:6

DTS HD Master Audio

DTS HD High Res Audio

MULTI/2 CH PCM/LPCM

Additional Modes

Bypass, Stereo, Party (all channels driven)

Dolby Surround: movie, music, night

DTS Neural X

11 channel processing

With assignable channels and Front Left and Right outputs allowing for:

7.1.2 and 5.1.4 configurations

5.1.2 configuration with bi-amped Front Left/Right channels

7.1.4 configuration with addition of a stereo amp for front speakers

Dirac Live EQ enabled

Limited Bandwidth subscription included,

Updateable to Full Bandwidth subscription

Digital inputs

Digital to analog Conversion

Chip set: 2 x ESS 9026PRO

Inputs

2 x TOSLINK (optical) up to 192kHz/24 bit; DoP 64/2.8MHz (bypass mode)
1 x RCA up to 192kHz/24 bit; DoP 64/2.8MHz (bypass mode)
1 x USB-B up to 768kHz/32 bit; DSD 512/22.6MHz; DoP 256/11.2MHz (2-channel only)

Video inputs and outputs

Inputs: 4 x HDMI 2.0b
Outputs: 2 x HDMI 2.0b – one each eARC and Aux

Matrix switching

OSD
3D and 4K UHD pass-through:
HDCP 2.2
RGB
YCbCr: 4:4:4; 4:2; 4:2:0
Dolby Vision, HDR, and HDR10+

Prisma Network Player (2-channel audio only)

Audio formats

WAV, AIFF, FLAC, ALAC, MP3, MP4 (AAC), WMA, OGG, DSD

Inputs

USB-A: up to 192kHz/24 bit; DSD 128/5.6MHz
AirPlay2®
Bluetooth®
Chromecast built-in®
Spotify Connect® (Spotify HiFi Ready)
UPnP/DLNA

LAN:

Up to 192kHz/24 bit; DSD 128/5.6MHz
Data transfer rate: 10/100Mbit

WLAN

Up to 192kHz/24 bit; DSD 128/5.6MHz
IEEE 802.11: 5GHz a/n/ac; 2.4GHz b, g, n
Data transfer rate: maximum of physical layer rate of 390 Mbps

General

Power consumption

Standby:

ECO < 0.5W

Normal < 6W

HDMI Pass-Through < 40W

Operating:

< 55W (left and right channel only)

< 85W (all channels)

Dimensions

430 x 420 x 142mm (WxDxH) with knobs and connectors

430 x 382 x 142mm (WxDxH) without knobs and connectors

Weight

12kg

Colour options

Black and Titanium



SP25 Prisma User Guide

CONTENTS

Safety information

Welcome!

Getting started

Back panel connections

Using the PRISMA remote

Using the SP25

Source options

Configuring the SP25

Setting up sources

Speaker configurations

Setting up speakers

Dirac Live

Other settings

Technical specification

Additional information

ADDITIONAL INFORMATION

These instructions help you get the best possible sound from your SP25.

Phase

The phase of the AC supply can make a significant difference to the sound.

Use the Polarity Pen supplied with the SP25 to verify which pin is live on your AC power cable.

Ensure that the live pin of the AC power cable is connected to the left-hand pin of the power connector, viewed from the back panel:

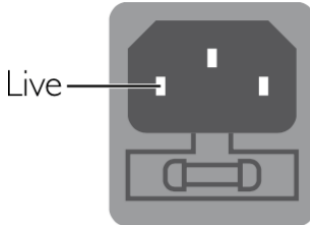

Burn-in

Your Primare will start to sound best after an initial burn-in of approximately 24 hours.

You will notice a further smaller improvement in sound quality for at least another 3 days' playing.

RS232 and trigger

The RS232 input allows you to connect the SP25 to a controller system. Use a twisted (null modem) cable. For more information contact Primare at info@primare.net or visit www.primare.net.

The Trigger output allows the SP25 to switch on other devices, such as a DD15.

Factory reset

Press and hold the  standby button on the front panel to display the main firmware version number.

Press and hold the  standby button on the front panel for 10 seconds to perform a factory reset of the SP25.

You can also do a factory reset from the Prisma app, or from the **General Settings** menu; see [Other settings: General settings](#).

Network troubleshooting

Front panel display

The front panel display indicates the type of network connection:

LAN indicates that you are connected by an Ethernet cable.

WiFi indicates that you are connected by wireless.

Network status

The **CON** indicator on the back panel indicates the network status:

ON Indicates the SP25 is connected to a network

OFF Indicates no connection to a network

Flashing indicates that the network needs to be configured using the Google Home app.

Spotify Connect

The Spotify Software is subject to third party licenses found here:

https://beta.developer.spotify.com/private-documentation/esdk-third_party_licenses