

VPL-GTZ380

4KSXRD 10,000 lumens Laser Light Source Projector

Achieve exceptionally bright, large scale image quality with this Native 4K resolution, super high contrast, DCI-P3 colorspace laser projector. In addition to unmatched optical performance, the VPL-GTZ380 comes in a convenient compact chassis and is equipped with a high performance picture processor, "X1 Ultimate for projector," to further enhance picture quality.



- Exclusive Sony SXRD panel provides native 4K resolution
- 10,000 Lumens brightness
- Laser Light Source with patented phosphor wheel
- "X1 Ultimate for projector" high performance picture processor
- Two HDMI inputs and two Display Port 1.4 inputs. Display Port 1.4 supports up to 4K 60P RGB444 10-bit signal with a single cable and up to 4K 120P RGB444 10-bit with dual cables.
- 4K 3D capability. With 4K 120P capability, the VPL-GTZ380 is capable of the Easy-on-the-eye dual 4K60P 3D active shutter system, which gives 4K 60P image to each eye.
- Wide Colour Space - Covers full DCI without brightness loss
- Smear reduction. The VPL-GTZ380 supports 25%, 41% and 50% of black insertion mode
- HDR support for HDR10 and HLG
- Powerful IR output for NVG training
- Deep blacks reduce white band visibility for multi-projector blending
- Long life optics, up to 20,000h (up to 40,000h in low brightness mode)
- Dust resistance by sealed optics
- Angle-free installation
- Robust chassis for easy handling and self stack capability
- Whisper quiet operation less than 39dB

All information and data given is preliminary as of June 2020

		VPL-GTZ380
Display system		4K SXRD panel projection system
Display device	Size of effective display area	0.74» (18.8mm) x3
	Number of pixels	26,542,080 (4096 x 2160 x 3) pixels
Projection lens*	Focus	Powered
	Zoom	Powered
	Lens Shift	VPLL-Z8008: Powered V:± 0.5V I H:± 0.18H VPLL-Z8014: Powered V:± 0.8V I H:± 0.31H
	Throw Ratio	VPLL-Z8008: 0.8:1 to 1.02:1 VPLL-Z8014: 1.4:1 to 2.73:1
Light source		Laser diode (Two Blue different wavelength lasers and Red laser)
Light output		10,000 lm
Colour light output		10,000 lm
Contrast ratio		16,000 : 1 (Native contrast) / ∞ : 1 (dynamic contrast)
Display resolution	Computer signal input	Maximum display resolution: 4,096 x 2,160 dots
	Maximum Video signal input	4K120P RGB 4:4:4 10bit (via 2x Display Port) 4K60p YUV 4:2:2 12bit (via HDMI)
Input / Output		HDMI (HDCP 2.3) x 2, Display Port (HDCP 2.3) x 2, RS-232C, 3D SYNC OUT (VESA 3D), IR IN/OUT, Trigger x 2, LAN, USB
Acoustic noise		39 dB
Operating temperature (Operating humidity)		5°C to 40°C (41°F to +104°F)/20% to 80% (no condensation)
Power requirements		AC100V to 240V, 50/60Hz
Power consumption		approx. 2.0KW 0.3 W
Heat dissipation		4,092 BTU/h
Dimensions		560 x 228 x 760 mm (22 1/16 x 8 31/32 x 29 15/16 in) (without protrusions)
		560 x 262 x 760 mm (22 1/16 x 10 5/16 x 29 15/16 in)
Mass		51kg 112 lb (excluding lens)
Optional accessories		VPLL-Z8014 (normal throw lens 1.4-2.73:1), VPLL-Z8008 (short throw lens 0.8-1.02:1) / Active 3D Glasses: X105-RF-X1

*The lenses are optional accessories.

VPL-GTZ380

PRELIMINARY VERSION

X1 Ultimate processor

"X1 Ultimate for projector" is a super high performance picture processor based on BRAVIA's flagship processor, X1 Ultimate



Wide-range laser control

High-end planetariums and simulators are required to dim the laser as low as possible to reproduce a deep-black night sky. The VPL-GTZ380 uses PWM (Pulse Width Modulation) laser control to be able to dim the laser power down to 10%.



Low transport delay

Transport delay is the time it takes for the projector to display the images received from sources. Having a low transport delay is critical for simulation and gaming applications. The VPL-GTZ380 achieves the same transport delay as the VPL-GTZ280, which is used in many simulators worldwide.



Smear reduction

In addition to 4K 120P high refresh rate interface, the VPL-GTZ380 has black insertion modes to reduce smear in fast moving video. There are three modes, 25%, 41%, 50%, which are the same as the ones of the VPL-GTZ280.



Laser light Source

The VPL-GTZ380 has a brand new laser light source design that includes an additional red diode. This enables the projector to achieve 100% DCI-P3 colour space without the need for colour filtering resulting in no brightness loss when using DCI-P3.

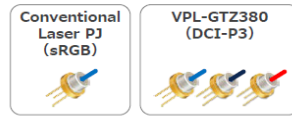

DCI-P3 is 100% covered
DCI-P3 is 1.35x wider than sRGB

Dual 4K60P 3D

With 4K120P capability, the VPL-GTZ380 is capable of the Easy-on-the-eye dual 4K60P 3D active shutter system, which gives 4K60P image to each eye. With 10,000lm brightness, the 3D brightness of the VPL-GTZ380 is more than double that of the VPL-GTZ270 or 280.

High Speed interface

The VPL-GTZ380 comes with two HDMI inputs and two Display Port 1.4 inputs. Display Port 1.4 supports up to 4K 60P RGB444 10-bit signal with a single cable and up to 4K 120P RGB444 10-bit with dual cables

Running quietly

The VPL-GTZ380 is one of the quietest high brightness laser projectors on the market, running at just 39dB. This is achieved by using a liquid SXRD panel cooling system and streamlined air flow design, with large fans running slowly and quietly in order to cool components like the laser light source.

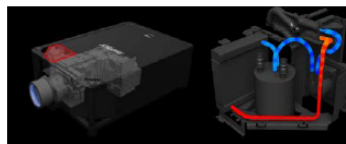

Sealed optics against dust

All optical components of the VPL-GTZ380 are sealed against dust, removing the need for a dust filter and therefore the inconvenience of regular cleaning.

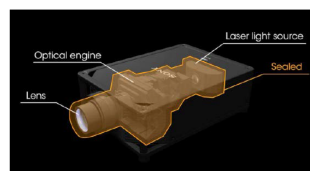

Dimensions

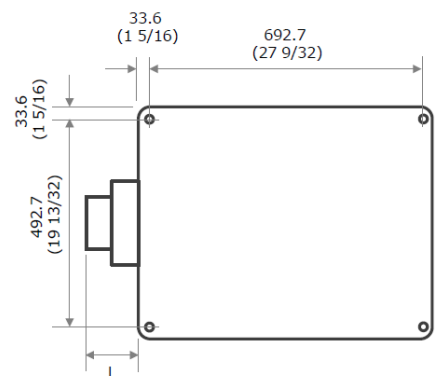
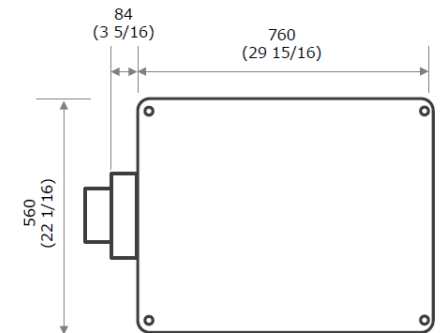
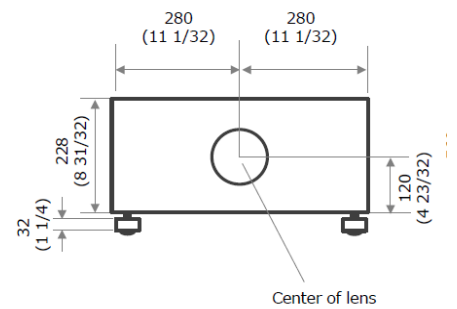

Unit: MM

The distance L is between the front of the lens (center) and the front of the cabinet.

Lens*

VPLL-Z8008 : 0.8:1 to 1.02:1
VPLL-Z8014 : 1.4:1 to 1.73:1

*The lenses are optional accessories.

IR Output for NVG training

Some of the most advanced simulators and training systems offer a night training scenario using night vision goggles (NVG). NVGs can detect Infra-Red (IR) light that is invisible to the human eye. The VPL-GTZ380 uses a dedicated LED light source to output 1.5 times brighter IR light than the VPL-GTZ280.



SONY

© 2020 Sony Corporation. All rights reserved. Reproduction in whole or in part without permission is prohibited. Features and specifications are subject to change without notice. All non-metric weights and measurements are approximate. Sony and BrightEra and their respective logos are trademarks of Sony Corporation. All other trademarks are the property of their respective owners. Errors and omissions excepted.

pro.sony